

PAMEL

42-300 Myszkow ul. Lesna 17 POLAND

REGULATOR POWER AND TEMPERATURE

PRM



www.pamel.biz pamel@pamel.biz

REGULATOR POWER PRM

Spis treści

PURPOSE	3
ADVANTAGES OF	3
OPERATION.....	3
DESTALAT mode.....	4
BREWERY mode.....	10
KCALIBRATION AND ADJUSTMENT OF POWER	19
Schemat podłączenia.....	21
Zanim zadzwonisz.....	22
SETTING THE ACTION SOLENOID.....	23
DISCLAIMER OF WARRANTIES.....	25

Before connecting and using the appliance please read this instruction manual.

If you have any problems understanding its contents please contact your dealer

device. Standalone installation and commissioning of the device is possible

provided that the

fitter basic knowledge. However, it is recommended to mount equipment by qualified personnel.

The manufacturer is not liable for any damage that may result from improper

installation or operation

device. Making unauthorized repairs and modifications resulting void the warranty.

The manufacturer reserves the right to change appearance, features, functions, and

technical parameters of the device

in order to improve the quality of the product.

Photos, drawings and texts used in this guide are

owned by Pamel.

PURPOSE

PRM is used for power control of the heating elements. Depending on the maximum power control is 3kW or 5.5kW (PRM +).

The device is not used to control inductive circuits, and light.

This can occur with buttons or pulse transmitter.

ADVANTAGES OF

It is simple to install and use , provides optimum power control heaters and one valve . Pulse does not wear out like a potentiometer . When it is rotated quickly provides quick changes when you need accurate adjustment just slowly turn the wheel encoder .

The device operates in several modes depending on the configuration . It can serve as a regulator power without probes

- controller with a probe while smoking, cooking , or brewing beer . ,

- two temperature controller that acts as a probe and the second probe above prevents the sausage temperature rises , or heat exchanger Kegua .

With the help of encoder revolutions user can adjust the power delivered to the circuit. Current power setting is displayed on the LCD.

To switch the operating mode before switching the power , press the knob. The unit switches to the next mode . Repeat until the desired mode .

The display can be set to display the image rotated 180 degrees. This allows the device may have the wires facing up or down .

OPERATION

DESTALAT mode.

It is designed to control the stills or chambers wędzarniczymi.

You can adjust the power manually (MANUAL) or let the driver choose the power automatically (PID).

In MANUAL mode using two buttons the user can adjust the power delivered to the circuit and the temperature to which the system is to aim or maximum The cleavage heater control. Current power setting and the temperature is displayed on the LCD.

In the event of power failure, the system stores the set power and temperature.

Setting is adjusted by turning the pulse transmitter power switch screens / temperature is done by pressing the button briefly during operation.

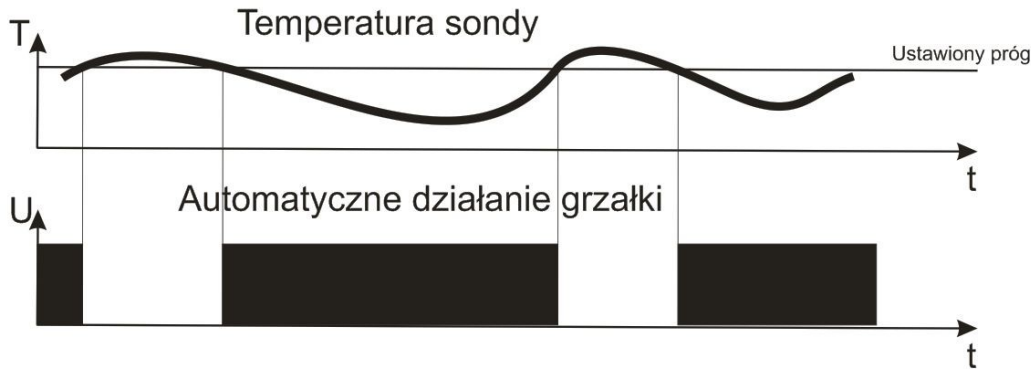

In PID mode, you can adjust the power delivered to the circuit and the temperature to which the system is to aim or maximum The cleavage heater control. Power is adjusted automatically depending on the temperature difference: current and expected. By adjusting the parameter WSP can adjust the power factor attributable to the difference in temperature. When a niedogrzewanie increase the ratio. When reduce overheating occurs.

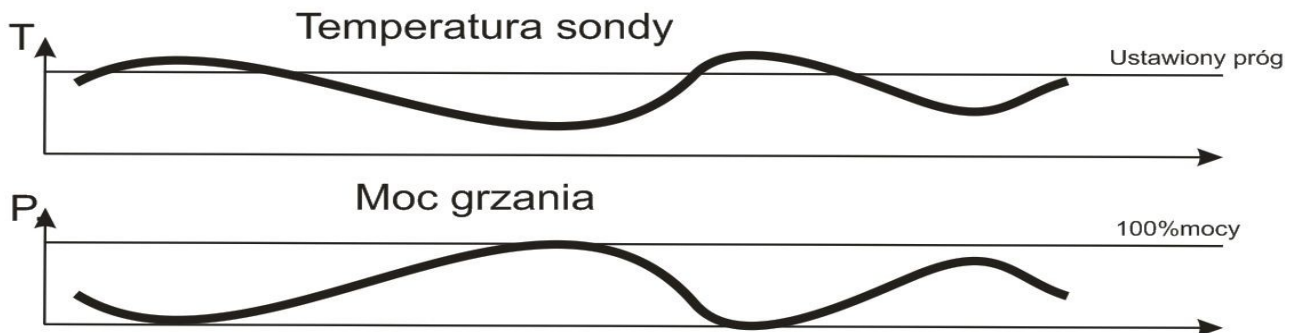

Where power is regulated by the formula $P[\%]=WSP*(T_{set}-T_{current})$.

Wpływ współczynnika PID na poziom mocy

dla ustawionej temperatury 74 stopnie

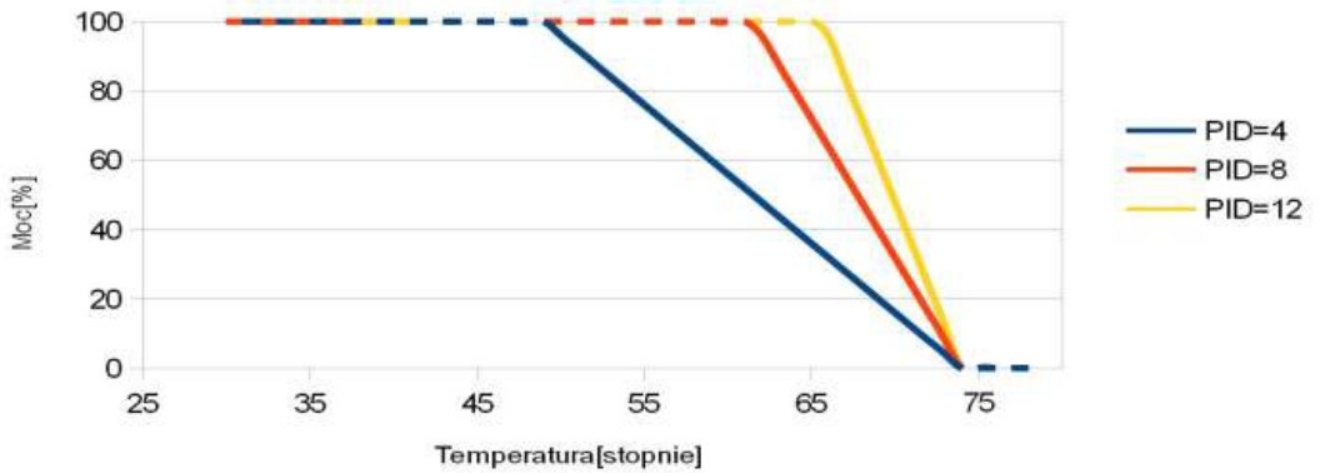

Switching between modes is done by entering the setup menu

In order to ensure better stability, you can choose a minimum power P_{min} which is added to the calculated power of the PID. This will cause the temperature at the time of achieving the desired heat to remain at e.g. 5%.

To enter the service menu to be on hold for longer. Short to change the image windows.
The first parameter is the control mode MANUAL / PID

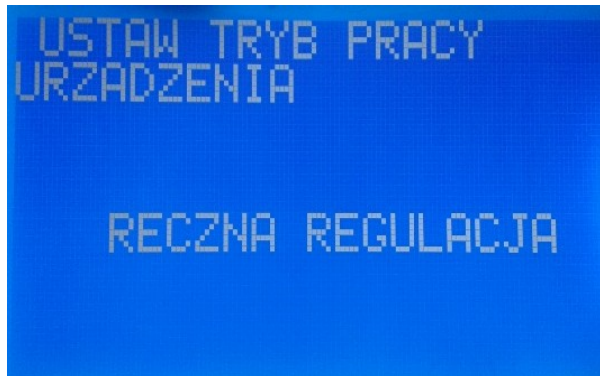

Then, you select whether the valve is installed.



Then, you select the type of valve that is normally closed or open.

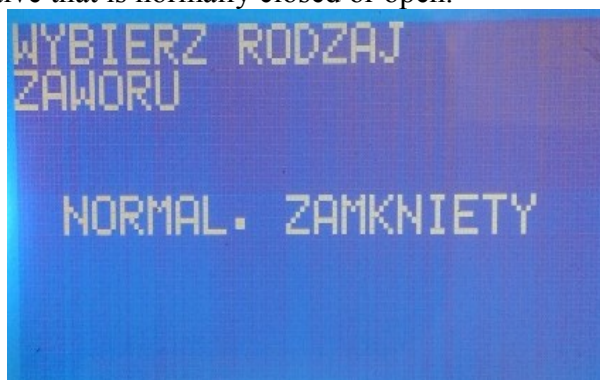

After selecting the type of valve is used to select the type of valve control HISTEREZA/OKNO/OKNO2



Then choose a probe that control the operation of the valve.

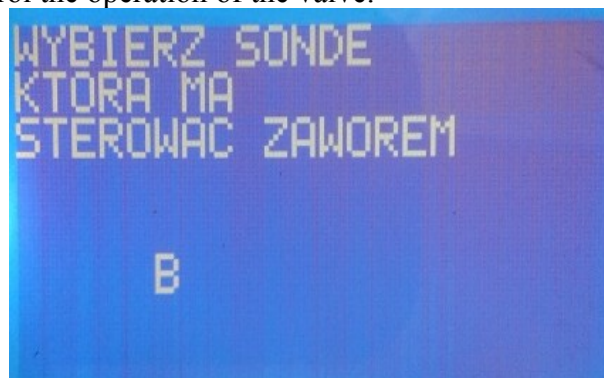

Then, this is the valve hysteresis settings (if you are working in this mode)

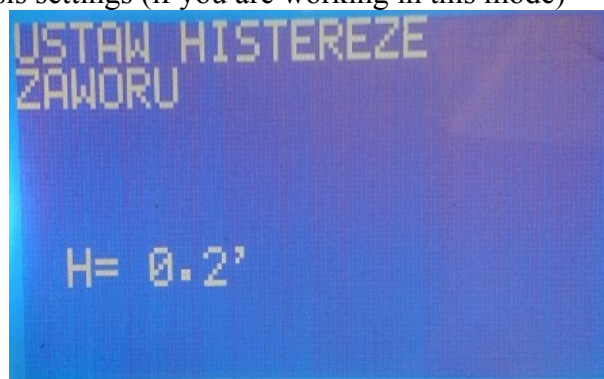

Then the definition of the selection of the power control mode MANUAL (0.25% or 1%)

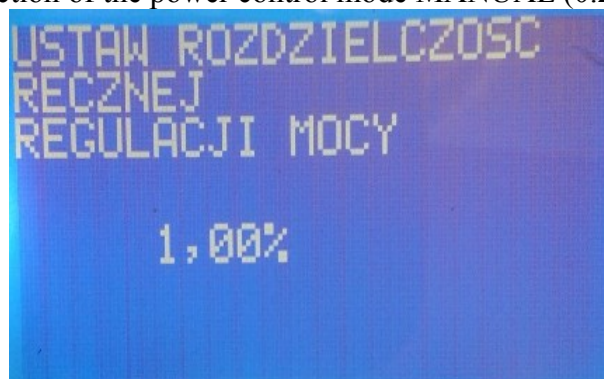

The controller has the ability to turn off after a set period of time.



Then you select whether to set the alarm temperature probe causing the end of the process.

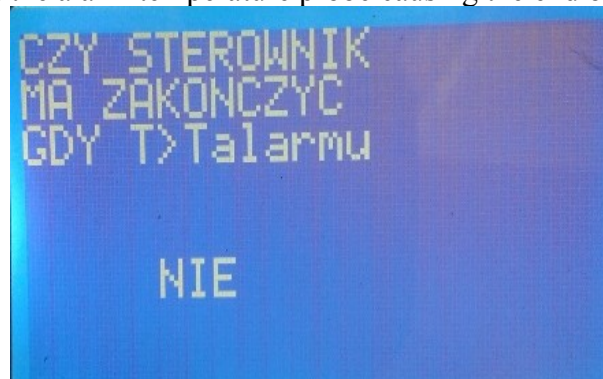

Then shall the temperature setting AUTOSTOP (if you are working in this mode)

Then you select which probe is cause AUTOSTOP (end process).

Then you select the operating mode sensors.

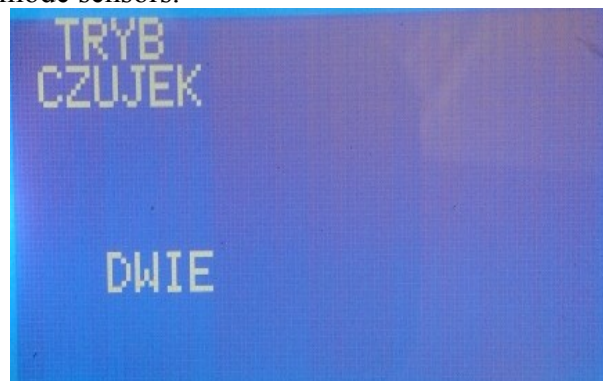

Then you select which probe is measured T1 and T2 which



Another parameter is the ratio of the power control in PID mode

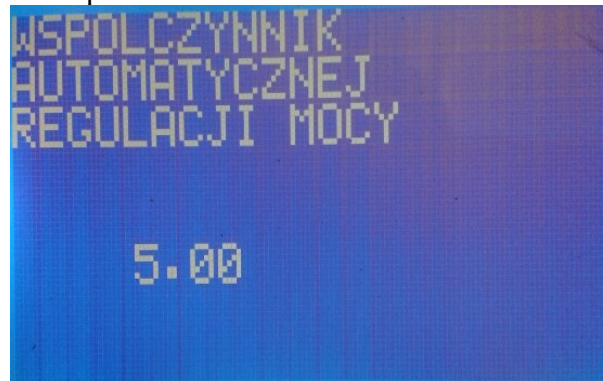

Then set the minimum output.

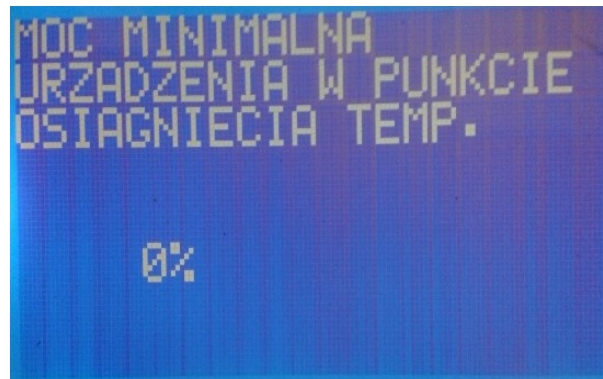

Then set the maximum power.

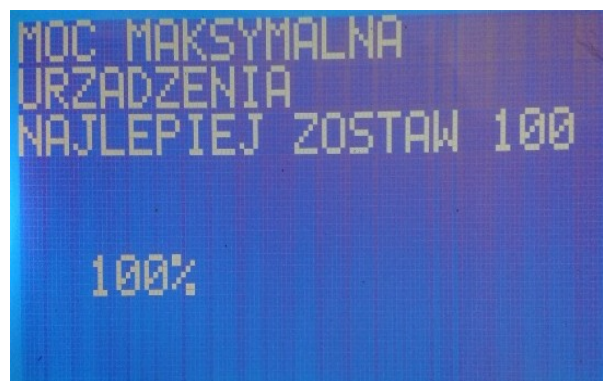

At the end the user can calibrate the probes (not recommended)

BREWERY mode

In this mode, you can divide the process of brewing up to 10 steps. For each stage, set the desired temperature and brewing time.

At any time the user can change the settings.

The advantage is the ability to store up to 5 processes (settings). Setting processes do not clear up after a power failure.

A second probe would serve to shut down when the user uses a heating heat exchanger for heating.

The user clicking the center button moves between several screens settings.

POWER WINDOW CONTROL

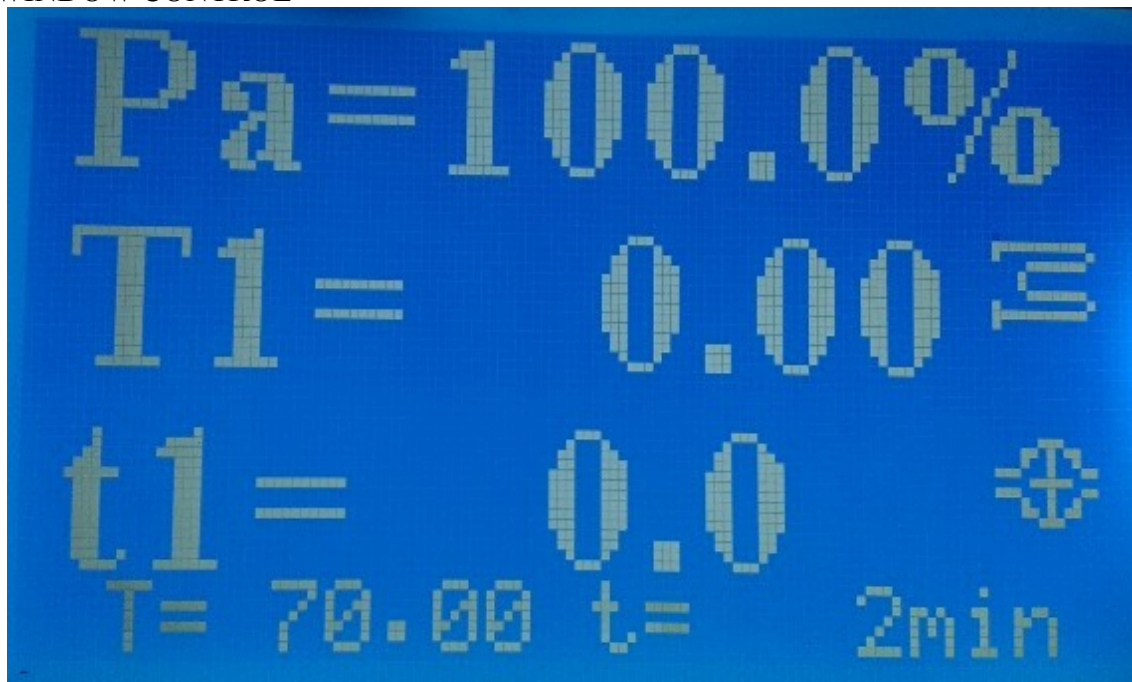

+ - Buttons you can adjust the power. If the display is the inscription Pa power is adjusted automatically.

P or Pa actual power

T1 current tank temperature of the stage

t1 the current time step

T the set temperature of the stage

t the time set the stage

SETTING THE STAGE TIME WINDOW

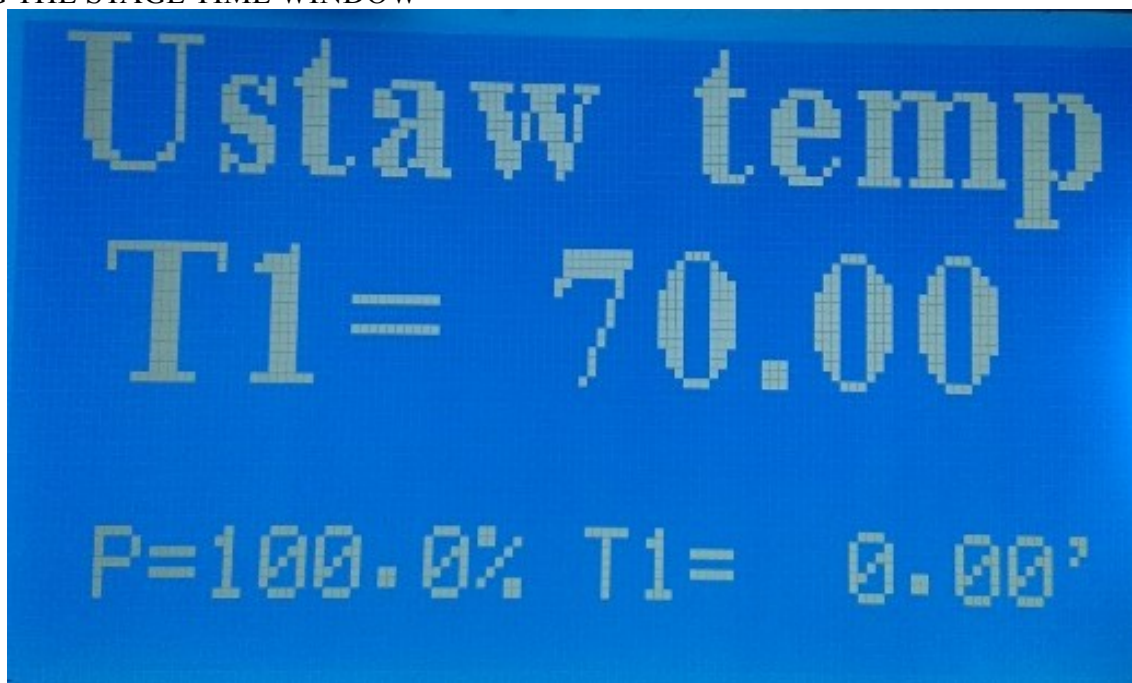

WINDOW SET DURATION STAGE

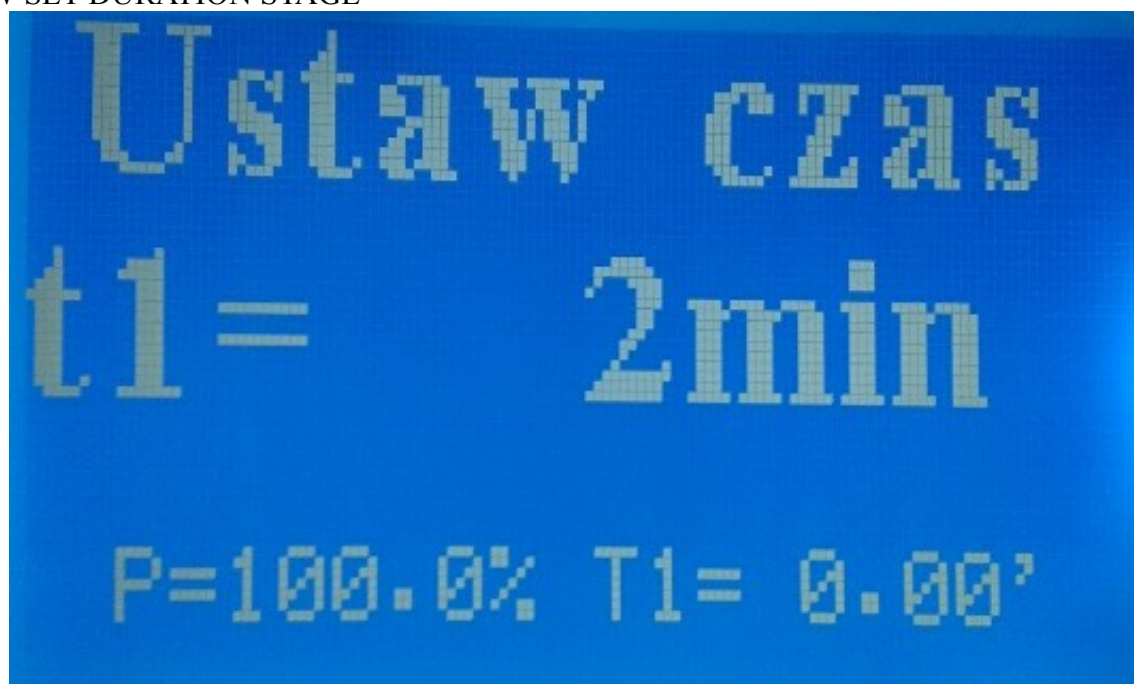

WINDOW SET EXCHANGER TEMPERATURE

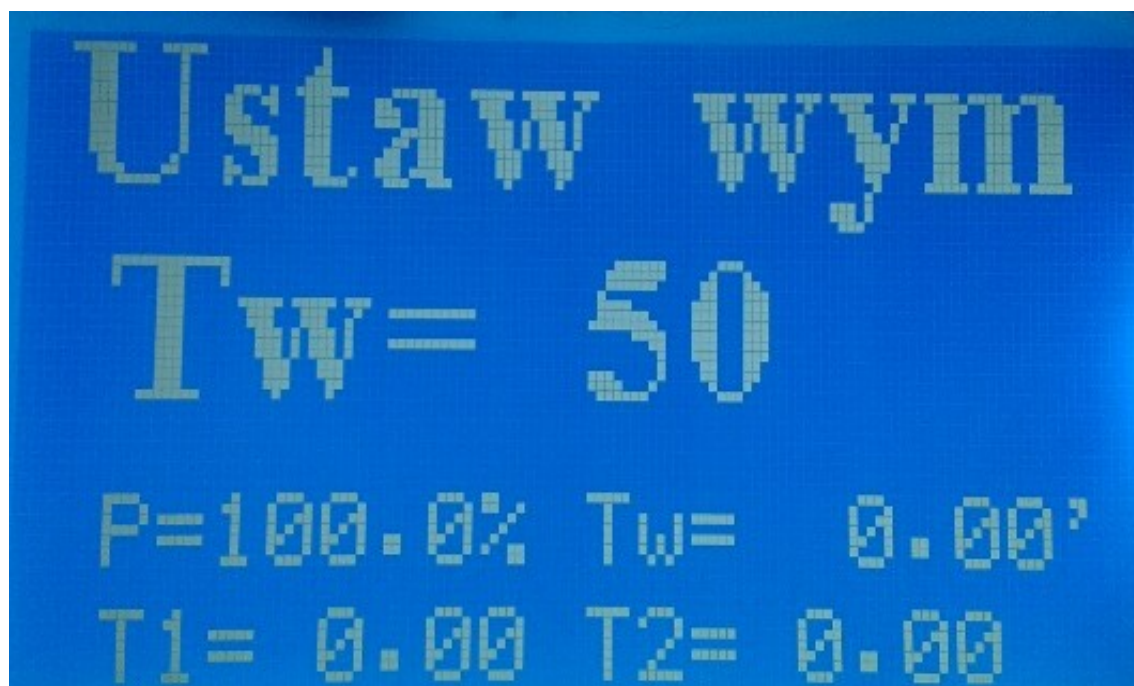

PAUSE SCREEN

The user may at any time temporarily stop the stage setting pause.

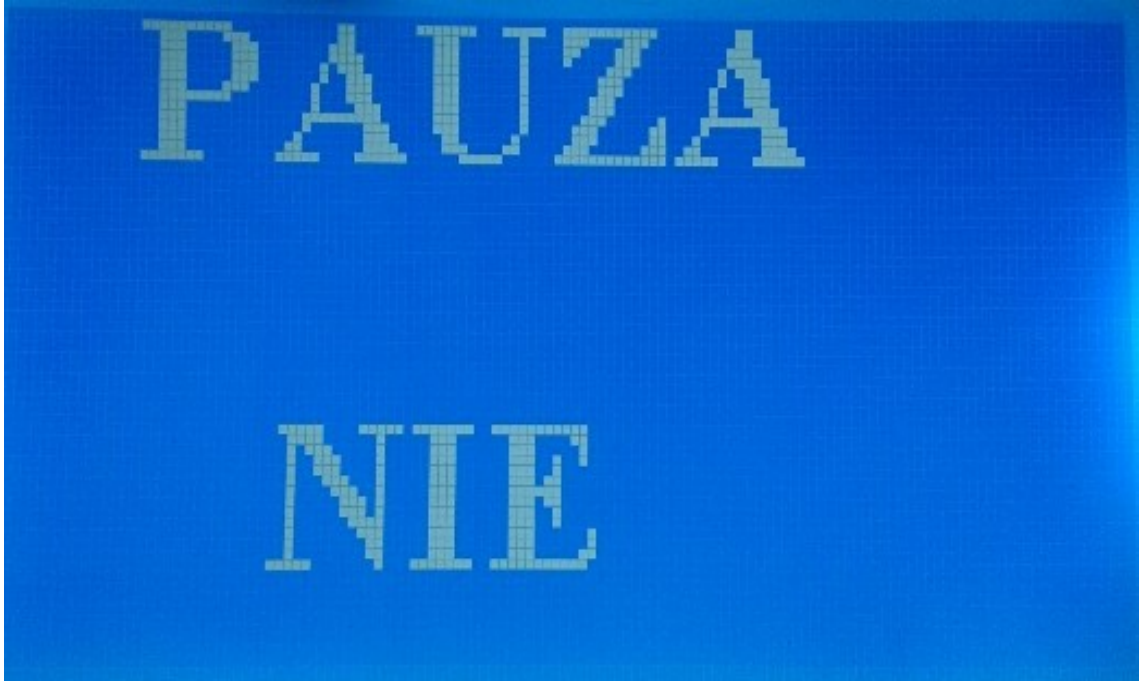

To enter the service menu to be on hold for longer. Short to change the image windows.
The first parameter is the control mode MANUAL / PID

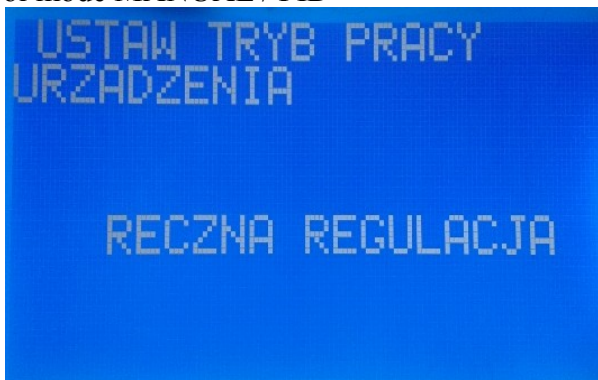

USTAW TRYB PRACY
URZADZENIA

RECZNA REGULACJA

Then select the resolution adjustment

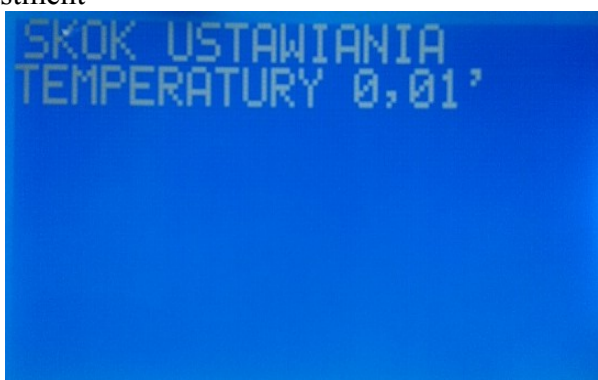

SKOK USTAWIANIA
TEMPERATURY 0,01'

Then you select the memory bank of stored process

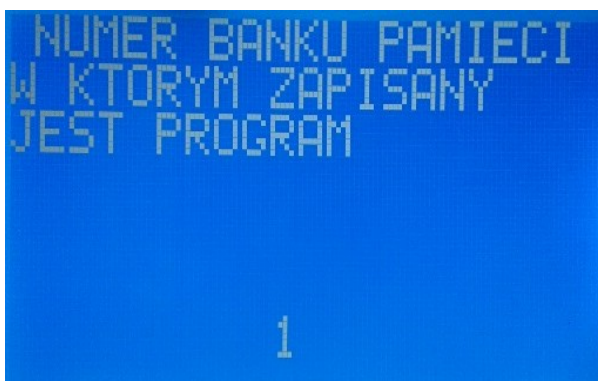

NUMER BANKU PAMIECI
W KTORYM ZAPISANY
JEST PROGRAM

1

Then you select number of steps.

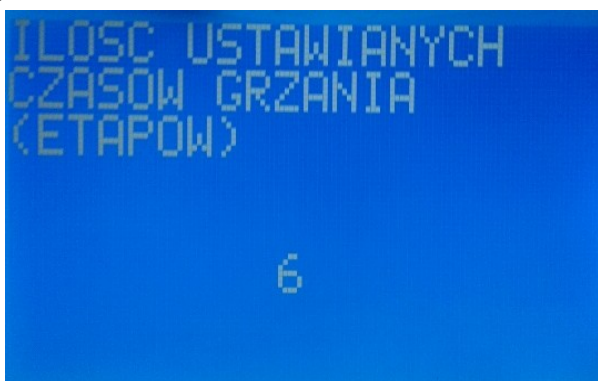

ILOSC USTAWIANYCH
CZASOW GRZANIA
(ETAPOW)

6

Then choose whether we will set the parameters for the stirrer

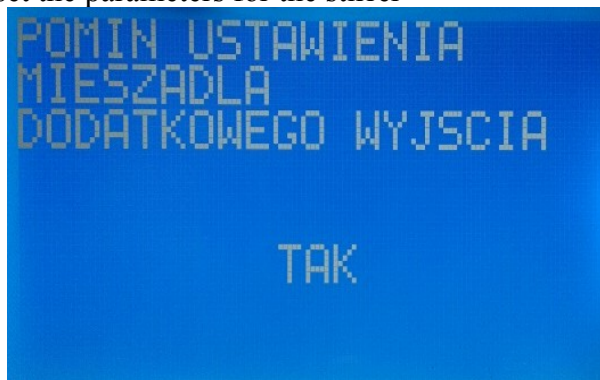

Another parameter is the ratio of the power control in PID mode for the appropriate stage

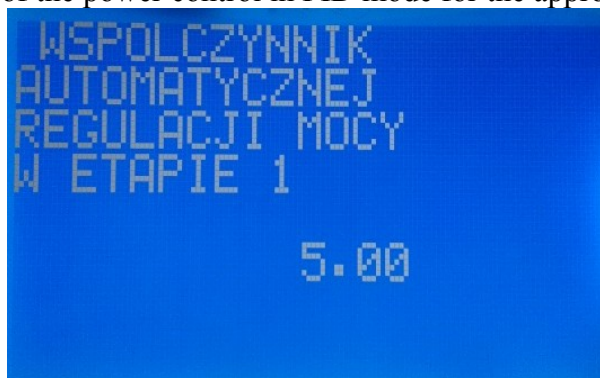

After selecting the type of valve shall be set until the appropriate stage



Then, this is the temperature setting appropriate stage



Setting parameters of individual steps must be repeated as many times as stages.
We set the parameters of the mixer

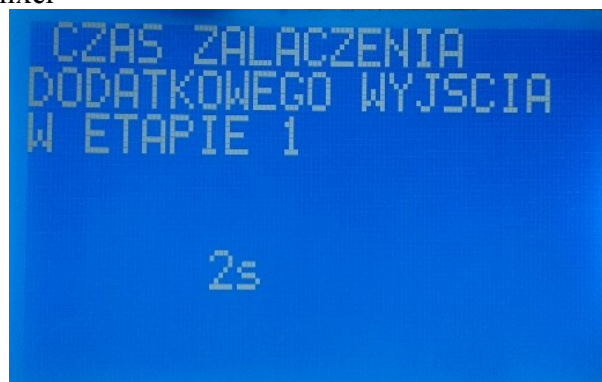

CZAS ZALACZENIA
DODATKOWEGO WYJSCIA
W ETAPIE 1

2s

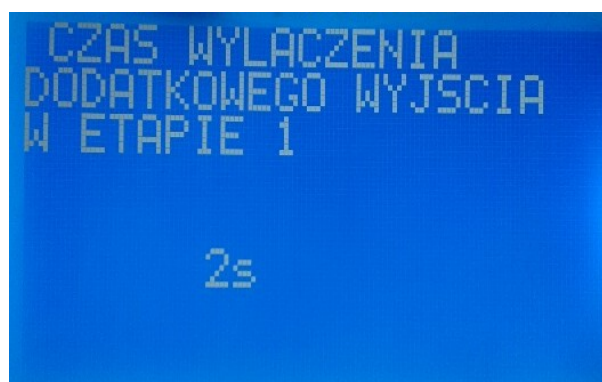

CZAS WYLACZENIA
DODATKOWEGO WYJSCIA
W ETAPIE 1

2s

Then set as is done counting time.



CO MA ROBIC GDY
SPADNIE TEMPERATURA
ZBIORNIKA?

IGNORUJ I LICZ DALEJ

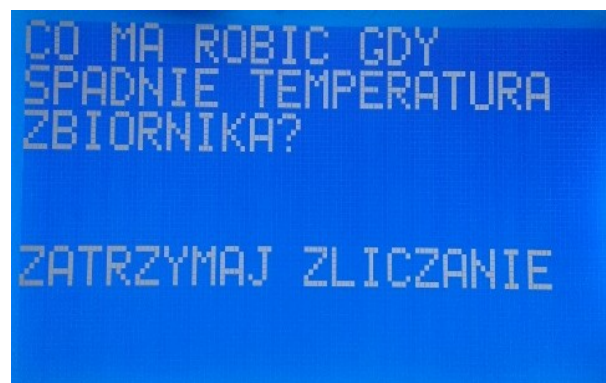

CO MA ROBIC GDY
SPADNIE TEMPERATURA
ZBIORNIKA?

ZATRZYMAJ ZLICZANIE

Then set if the driver has to control the temperature of the heat exchanger.



CZY JEST WYMIENNIK
CIEPLA?

NIE

Set as when to start counting time after the transition to the next stage

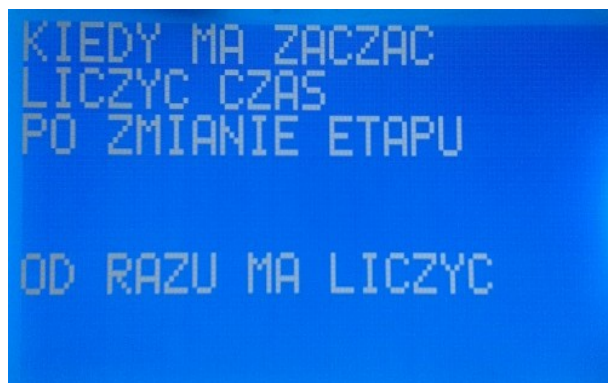

KIEDY MA ZACZAC
LICZYC CZAS
PO ZMIANIE ETAPU

OD RAZU MA LICZYC

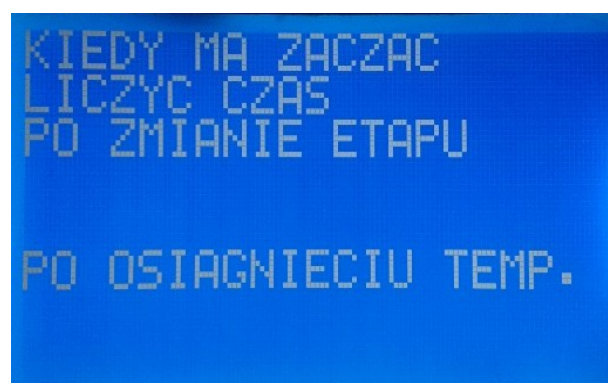

KIEDY MA ZACZAC
LICZYC CZAS
PO ZMIANIE ETAPU

PO OSIAGNIECIU TEMP.

Set the machine what to do after the stage. Does it automatically go to the next or wait for adding ingredients.

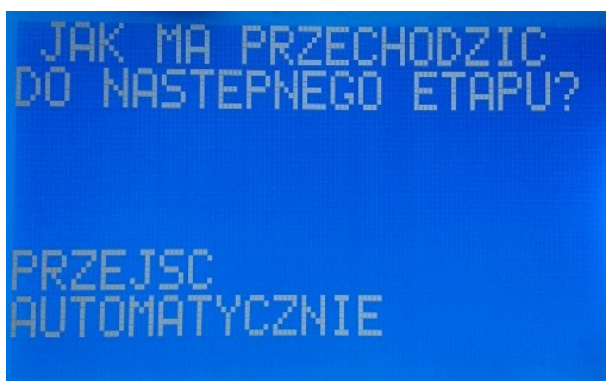

JAK MA PRZECHODZIC
DO NASTEPNEGO ETAPU?

PRZEJSC
AUTOMATYCZNIE

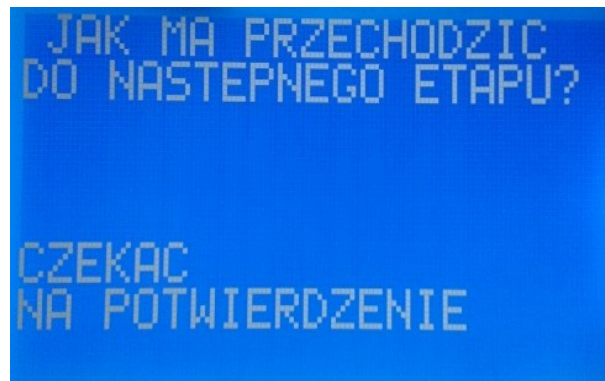

JAK MA PRZECHODZIC
DO NASTEPNEGO ETAPU?

CZEKAC
NA POTWIERDZENIE

If the unit is to control the temperature of the heat exchanger are next set to the maximum temperature

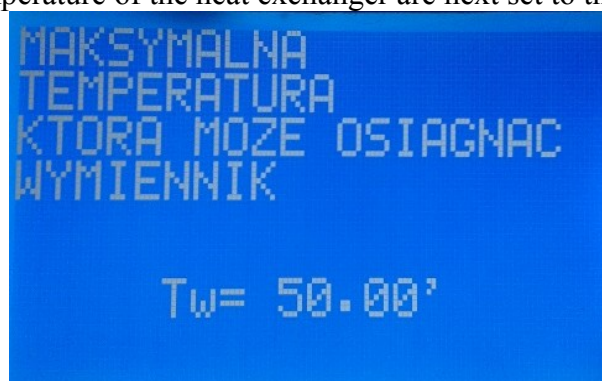

MAKSYMALNA
TEMPERATURA
KTORA MOZE OSIAGNAC
WYMIENNIK

Tw= 50.00'

Then set the minimum output.

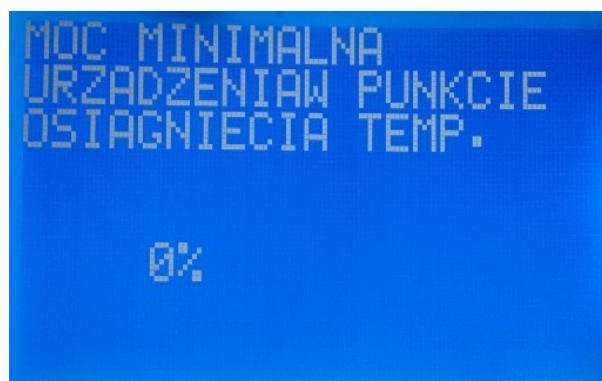

MOC MINIMALNA
URZADZENIAW PUNKCIE
OSIAGNIECIA TEMP.

0%

Then set the maximum power P_{max}

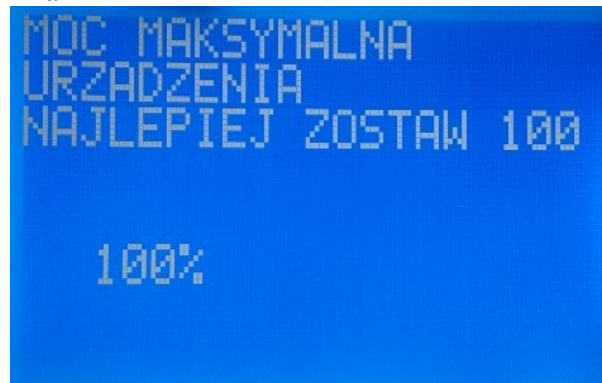

At the end of the set the driver what to do immediately after power-up.

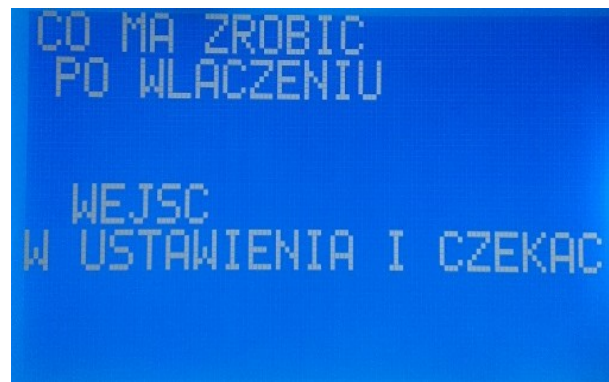
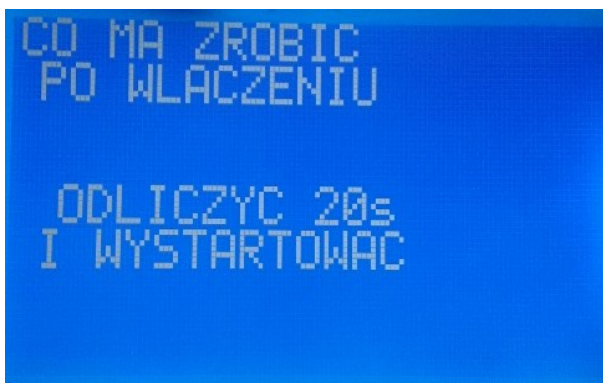

At the end the user can calibrate the probes (not recommended)

KCALIBRATION AND ADJUSTMENT OF POWER

In order to ensure the accuracy of the process, the user can calibrate the probe.

It should no longer hold the center button after power user performs calibration and adjust the power factor.

Touching fields "+" "-" set power factor WSP. The setting and confirm by pressing the middle button "O".

To probe the "+" "-" set the linearity coefficient (slope) "B", which causes the indication

$T_{\text{displayed}} = B * T_{\text{sensor readings}} + A$ The setting of the middle mouse button to confirm the "O".

Window appears the temperature calibration of the index A.

Then the "+" "-" set shifting "A" which will cause a $T_{\text{displayed}} = B * T_{\text{sensor readings}} + A$.The setting of the middle mouse button to confirm the "O".

It is recommended to leave the default $B = 1.25$ and $A = 0$

"B" to adjust the temperature with an increase in the difference of the temperature indication of the expected increases or decreases. For example, at room temperature, the temperature is underestimated by 0.1 degrees and 80 degrees with a 0.3 degree.

"A" to adjust when with increasing temperature difference from the expected temperature indication is constant. For example, the temperature in the whole range is underestimated by 2 degrees.

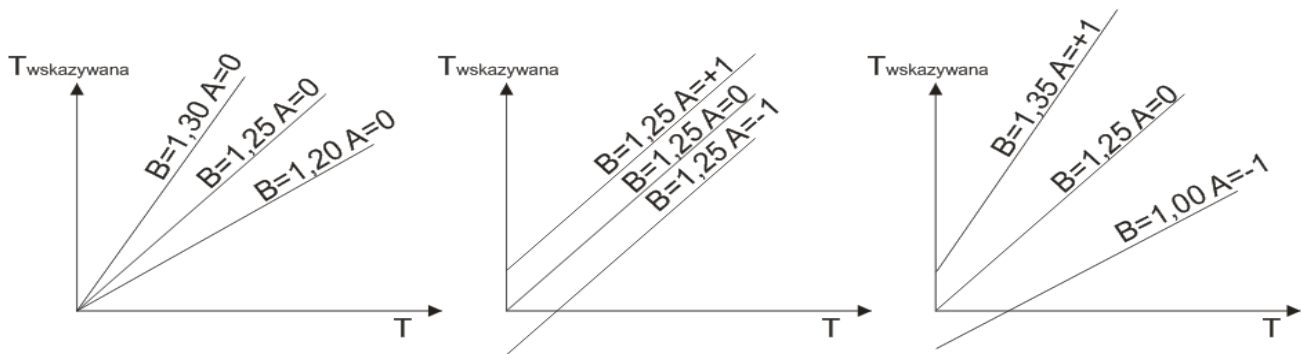

SYMPTOM	ACTION
The thermostat lowers the temperature indicated by a constant value, eg 2 degrees	Set the value of the correction A "0" to "-2"
Thermostat overstates the indicated temperature by a constant value, eg 2 degrees	Set the value of the correction A "0" to "2"
The thermostat lowers the temperature indicated for example, 10 percent	Increase the correction value B for example, for "01" eg from "1.4" to "1.5"
Thermostat overstates the indicated temperature for example, 10 percent	Decrease value of the adjustment B eg "01" for example, "1.4" to "1.3"
The combination of the above	The combination of the above

The temperature indicated assumes the value $T_{\text{displayed}} = B * T_{\text{sensor readings}} + A$ and depends on the set adjustments.

Default:

$A = 0$

$B = 1.25$

The unit is supplied pre-calibrated. If your thermometer shows 19 degrees does not mean that such a temperature prevails throughout the room. The difference in temperature mainly depends on the height and mounting location of the sensor, for example, there is a different temperature in a room closer to the radiator, the floor, the ceiling, element wooden, metal or by the window.

Analogous behavior of the temperature in the unit (the still smokehouse). The temperature can vary depending on the mounting location, method of installation, thermal conductivity, etc. That's why we left you can manually calibrate the probes.

Probe calibration is not necessary.

SPECIFICATIONS

Voltage:	230V +10% -20%, 50Hz
Operating temperature:	-10 to +60 ° C
Output load capacity:	3kW (5.5 kW PRM +)
Maximum Power Consumption:	1.5 W
Power control Resolution:	0.25% or 1%
Temperature resolution of	0.025 degree
Maximum number of probes	2
Dimensions:	L-180mm, width,-130mm, height - 40mm
Housing:	self-extinguishing
Degree of protection:	IP20
Compliance with standards:	EN 60529
The product does not contain lead (Pb-Free)	

Due to the versatility of the probe is not included in the kit. Must be purchased separately.

Due to the rounding of the displayed values to two decimal places in accordance with the rules of rounding 0.025 is rounded to 0.03; however, 0.075 to 0.08. This is only for display rounding. The algorithm constantly occur of an accuracy of .025 degree.

Schemat podłączenia.

UWAGA!!!!

**PE OZNACZA
PRZEWÓD OCHRONNY
PODŁĄCZENIE
NIE JEST WYMAGANE
DO POPRAWNEJ PRACY**

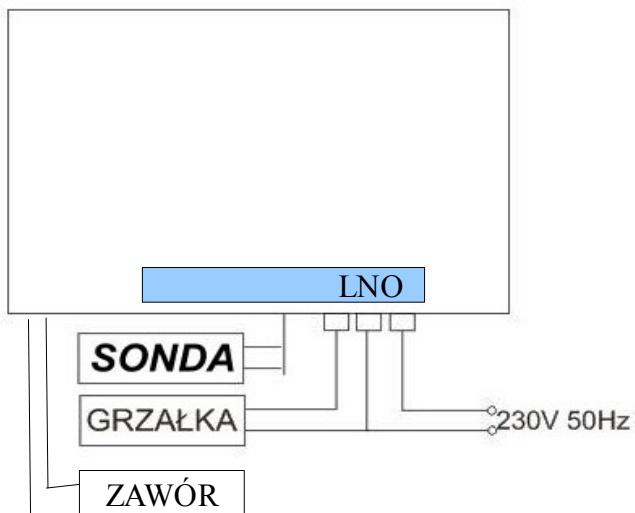

Wersja z zaworem

PE			ZAWÓR1	ZAWÓR1	L	N	O
----	--	--	--------	--------	---	---	---

Wersja bez zaworu

PE		L		N		O
----	--	---	--	---	--	---

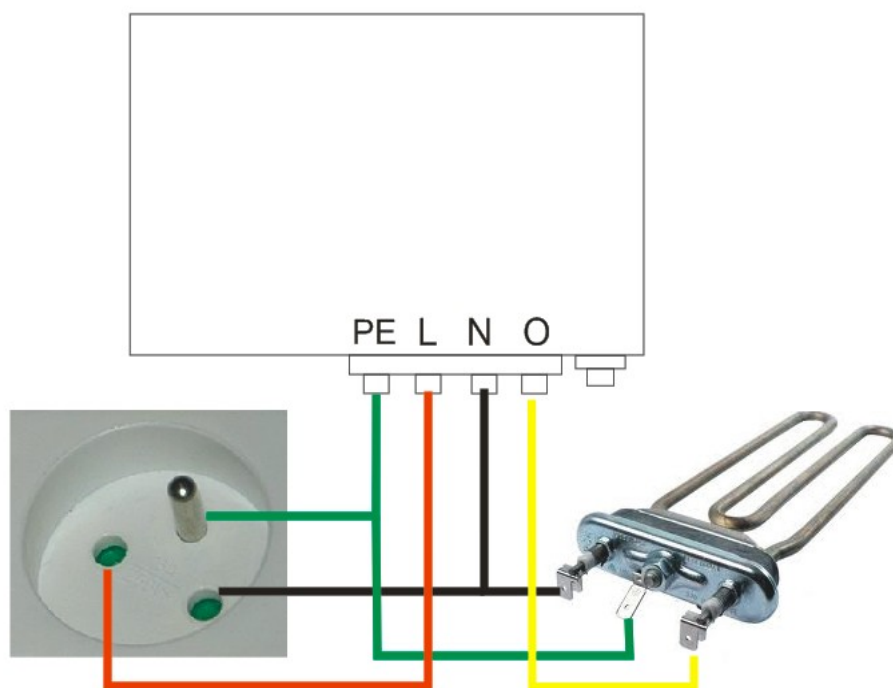

Zanim zadzwonisz.

Objaw	Wskazówka
Zbiornik nie osiąga właściwej temperatury	W trybie manual zwiększ nastawioną moc. W trybie PID zwiększ współczynnik PID lub moc minimalną. Wymień grzałkę na grzałkę o większej mocy.
Grzałka nie włącza się	Sprawdź czy nie zamieniono zacisków „O” i „L”. Sprawdź czy grzałka jest sprawna. Sprawdź bezpiecznik.
Przygasa światło	Przygasanie światła spowodowane jest przeciążeniem instalacji elektrycznej. Każde 2kW mocy grzałki to prąd dochodzący do 5A co przy starej instalacji lub cienkich przewodach może powodować spadki napięć. Należy sprawdzić bezpieczniki w mieszkaniu.
Odwrotne wykrywanie sond	Wejdz w ustawienia i zmień KOLEJNOŚĆ SOND
Sterownik jest ciepły	Urządzenie działa prawidłowo. Większość wzmacniaczy, telewizorów, ładowarek telefonów komórkowych jest ciepła. Urządzenie posiada zabezpieczenie termiczne. Gdyby temperatura była zbyt wysoka sterownik automatycznie wyłączy sterowanie.
Sterownik jest bardzo gorący, brak sterowania.	Urządzenie posiada ograniczenie mocy maksymalnej. Grzałki elektryczne produkowane są z różną tolerancją np 10 a nawet 20%. To oznacza że np grzałki o łącznej mocy 3,5KW mogą obciążać urządzenie z mocą prawie 4kW (przy 10% tolerancji). Jeśli grzałki nie są badane że pobierają maks 3,5kW należy zastosować pewien zapas mocy.
Sterownik nie wykrył sond	Sondy należy podłączyć przed uruchomieniem sterownika Uszkodzona sonda, podłącz tylko jedną sondę i sprawdź czy jest wykrywana
Napisy są wyświetlane do góry nogami.	W czasie uruchamiania sterownika przytrzymaj środkowy przycisk i zmień obrót na 0

SETTING THE ACTION SOLENOID

In the version with access to the solenoid, you can set the temperature at which it is to be triggered (off) solenoid.

The valve can operate in three modes: DEADBAND, WINDOW, OKNO2

To change the mode of operation of the valve must enter the service menu and set the appropriate mode.

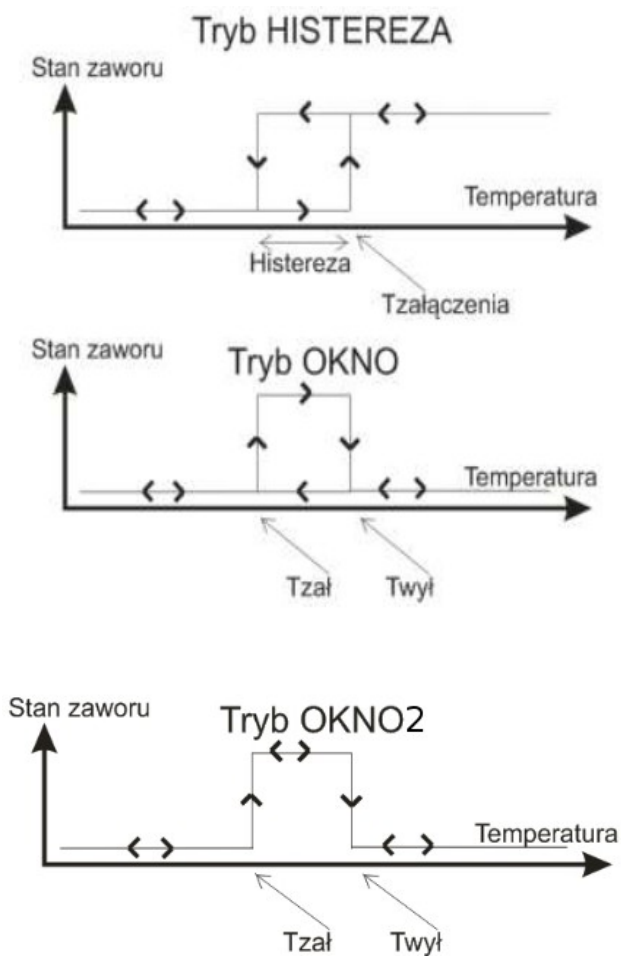

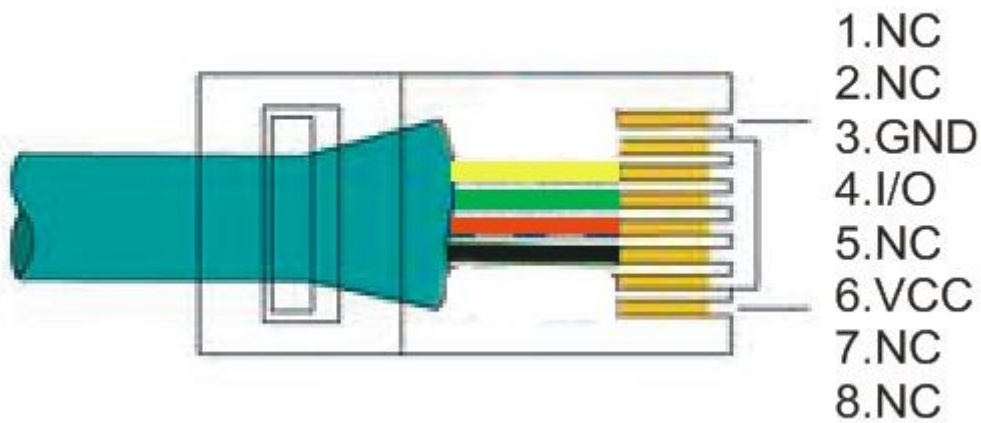

PAMEL 42-300 Myszkow ul. Lesna 17 POLAND

Dear User,

At the outset, we would like to thank you for choosing a product from PAMEL. We are sure that you will be pleased with this choice. We design our equipment to meet your requirements and ensure future smooth operation.

Before using the equipment should be thoroughly familiar with installation procedures and operating conditions described in the Instruction Manual.

If in doubt, please contact us.

791-607-644 (OFFICE hours 9-15)
609-703-931(SUPPORT hours 13-23)

DISCLAIMER OF WARRANTIES.

1 PAMEL warranties in the Polish Republic for a period of 30 months from the date of sale (or 12 months beyond Polish), but not longer than 60 months from the date on the Product , which is issued warranty card provided to use the equipment in accordance with specifications and technical-operational terms described in the User's Manual.

2.Gwarancją are not covered by mobile equipment product (accessories) to be assembled by the user , eg, antennas , sensors, brackets , cables , batteries, power .

3 Guarantor agrees to free removal of physical defects , if such defects become apparent during the warranty period or until the item is delivered free of defects , if within guarantees have been made at least 4 repairs subject and the object of sale is still defective.

In case of replacement, the product will be replaced with a new model of the same or of similar , not worse technical parameters. If such an exchange is not possible , the Buyer will receive a refund of payment.

3 The warranty period provided for in point 1 shall be extended by the duration of the repair.

4 The duration of the repair period is counted from the date of delivery subject to a service the date of issue subject to the carrier delivers it to the Buyer .

5 In the event of a defect the Buyer shall notify the Guarantor , via email

website (pamel@pamel.biz) the Guarantor or phone will first try to resolve the problem remotely and points the way forward the complaint procedure .

6 At the request of the Guarantor buyer is obliged to reliably fill the Complaint Report Protocol provided by the Guarantor .

7 The guarantor is liable only for defects resulting from causes inherent to sell .

8 Warranty does not cover damage caused by improper or

improper installation and assembly for use in particular , storage , maintenance, incompatible with the intended use, improper use of consumables,

willfully making repairs or improvements, mechanical damage due to the fault

user from external causes such as pollution , flooding, condensation , atmospheric phenomena , random events . They are not covered by the warranty also damage electronic components resulting from the cross-rating .

9 Warranty does not cover claims arising from technical parameters , if they are as given by the manufacturer.

10 The condition for preservation by the Buyer of warranty is to provide

device to a service referred to in paragraph 5 , are complete , the

packaging reduces the risk of damage , documentation , cables and all other elements issued in connection with the contract of sale, no broken seals or stickers along with the warranty card .

11 warranty does not cover materials and activities in the normal operational service , such as installing hardware , programming, cleaning and maintenance , replacement of light bulbs and fuses , check the operation . Services mentioned above are paid.

In the case of an unjustified complaint (complaint efficient equipment or when the damage was the fault of the customer) who submitted the complaint will be charged expertise and transport.

12 Point Service in addition to situations referred to in paragraph 7-11 may refuse to warranty repairs and in case of:

- Declaration that the data contained in the sales documentation of data device

- Application of amendments in documents by unauthorized persons

13 Defects device disclosed in the warranty period will be removed within 21

days , counted from the day following the day of delivery to the point of

service . If you need to import spare parts from abroad

Guarantor reserves the right to extend the warranty period for the time necessary to

repair , as buyer will be informed each time using

email.

14 The unit should be installed in accordance with the required standards, technical requirements contained in the manual. If there is a legal requirement to mount the device has to make a person with appropriate empower in this regard.

15 The rights and obligations of the parties in respect of guarantees governs only the content of the provisions in herein.

16. Sprzet not received the service within three months of completion of the repair shall be forfeited in favor of the service.

17. W when warranty repair requires replacement , the replaced remains the property of the Guarantor .

18. Gwarant is not liable for damages resulting from the loss of user data stored on your device , we inform that the device will be returned in accordance with the state of production .

