



42-300 Myszkow ul. Lesna 17  
POLAND

POWER CONTROLLERS

# **SERIES 3**

PRD3+, PRD3W+



PRD3 DUO



PRD3F, PRD3F DUO



**PLEASE READ THIS MANUAL CAREFULLY**  
**YOU DON'T KNOW SOMETHING? CALL US! WE DON'T BITE**  
**791-607-644 (OFFICE 9 A.M. – 2 P.M., weekday)**  
**609-703-931 (SUPPORT 4 P.M. – 9 P.M., whole week)**

[www.pamel.pl](http://www.pamel.pl) [pamel@pamel.pl](mailto:pamel@pamel.pl)

# POWER REGULATORS SERIES 3

## Table of Contents

PURPOSE OF THE DEVICE.....	4
ADVANTAGES .....	4
OPERATION .....	5
SETTING THE TEMPERATURE ALARM.....	6
Calibration of the temperature indicated.....	7
SETTING PERFORMANCE SOLENOID (mode of distillation).....	8
HYSTEREZE mode.....	8
WINDOW mode.....	8
WINDOW mode 2.....	9
SETTING POWER HEATER MANUAL MODE.....	10
SETTING THE AUTOMATIC ADJUSTMENT POWER.....	10
SETTING MODE.....	12
SETTING YOUR NICK.....	12
SETTING THE NAMES OF INDIVIDUAL PROBE.....	13
TEMPERATURE CHARTS.....	13
ADJUSTMENT LCD.....	14
CHANGE THE ORDER OF THE PROBES.....	14
ADJUSTABLE FEATURES MENU SERVICE.....	15
DESCRIPTION OF SERVICE SETTINGS MENU.....	15
SPECIFICATIONS .....	19
LAYOUT:.....	20
PRD3+.....	20
PRD3W+, PRD3W DUO.....	21
PRD3F.....	23
PRD3(W)+ with wires.....	23
STRANGE SYMPTOMS OF EQUIPMENT-TIPS BEFORE YOU CALL.....	24
PORTS OF PROBE.....	25
FIRST TIME DRIVER.....	26
DISCLAIMER OF WARRANTIES.....	27

**NOTE!**

**The buttons are used to press, they are not intended to tapping.**

**Button, press and hold. While holding the setting changes**







**for example, about 0.1 degree value. For longer hold the value of the jump tenfold value begins to change, eg by 1 degree value.**

**With this work it is possible to set up a very accurate and very fast.**

**In the version with pulse pressing the knob is pressing the center button. Turning to the right, left, replaces the "+" "-"**

**Please read this manual carefully before connecting and use of this device.**

In case of any problems with understanding its content please contact with the dealer. Own assembly and start-up of device is possible if fitter has basic knowledge. Nevertheless it is recommended to assembly this device by qualified staff. Manufacturer holds no responsibility for damages resulting from improper assembly or exploitation of device. Own repairs and modifications results in loss of warranty. Manufacturer reserves the right to change look, features and technical parameters of the device in order to increase product quality. Images, drawing and lines used in this manual are property of PAMEL company.

	<p>Do not dismantle or modify.</p> <ul style="list-style-type: none"> <li>• It can cause breakdown</li> <li>• Contact authorized service if needed</li> </ul> <p>We don't bite. It will be cheaper than own repair or modification</p>
	<p>If you don't use device for longer period of time then disconnect power.</p> <p>If you want to do electronic works e.g. change of wires then disconnect power.</p> <p>Electrician also can be shocked.</p>
	<p>Avoid leading power cable through spots where people walk.</p> <ul style="list-style-type: none"> <li>• Someone can latch onto cable and throw device down causing its damage and hurting staff.</li> </ul>
	<p>Don't touch with wet hands.</p> <ul style="list-style-type: none"> <li>• Electrocuting possibility.</li> </ul>
	<p>Do not use device in place when it is exposed to fluids.</p> <ul style="list-style-type: none"> <li>• It can cause short circuit or electrocuting.</li> </ul>
	<p>Do not place device in dusted areas.</p> <ul style="list-style-type: none"> <li>• There is a risk of bad cooling and work of thermistor.</li> </ul> <p>Nobody like dirt, especially fans.</p>

Series 3 The device is used to power control of the heating elements . Depending on the maximum power of 5.5 kW adjustable for single-phase devices and 3x5, 5 kW three-phase devices .

It does not require a uniform loading of all outputs .

Depending on the version of the heater can be powered by 230V, 3x230V ( star) or 3x400V (triangle)

The device is not used to control inductive circuits , and light .

This allows temperature measurements at four points (5 probe attached via HUB ) and the information gathered controls the heating processes (turning on the heater ) or cooling ( cooling water solenoid switching or ARC ) . Depending on the version of the device is from 1 to 3 valve outputs 12V or 230V 100W output.

You have the ability to set the audio and visual alarms and safety temperature at which the heat turns off .

During the distillation device operates by measuring the effect of any selected one of the probes.

In this mode the user can select the smoking of which will be averaged temperature probes , which are used only for viewing the temperature.

Smoking is carried out in 3 stages (heating , drying , smoking ) . The time and temperature during different stages of programmed before the cycle. The parameters can be changed during operation. In addition, controls the fan and pump smoke.

In this mode the user can choose the brewing of which will be averaged temperature probes , which are used only for viewing the temperature.

Brewing takes place in a stepwise one . Time and temperature are programmed during brewing cycle before . The parameters can be changed during operation.

## **ADVANTAGES**

It is simple to install and use , provides optimum power control heaters , valves and other auxiliary equipment .

Easy to read graphic display visualizes the processes well .

The user can enter your own nickname is 8 characters when you start the machine . Similarly , the names of the probes .

At any time there are graphs of temperature versus time for optimal supervision processes .

Probe with a length of 1.5 meters allow free placement of sensors . Opportunity to buy a HUB , Which concentrates signals in one cable Extending further .

The device has a Possibility of automatic power control , depending on the temperature difference measured by probes , and set by the user ( PID) . Depending on the version , you can connect a liquid level sensor protects against damage That is the heater .

**The device can be used both for distillation , smoking and brewing .**

**It has protection against overheating of the product and the cooling system forced .**

**To save energy . Setting the example , 50% of the heating Causes power consumption reduced by 50%. The remaining energy is not lost in the system , it is not at all drawn by the heater .**

## OPERATION

With three buttons the user moves the graphical menu. Short press the button changes by 1 unit, eg 0.1 degree. Press and hold to accelerate change.

The device may adjust the power supplied to the circuit. Current power setting is displayed on the LCD.

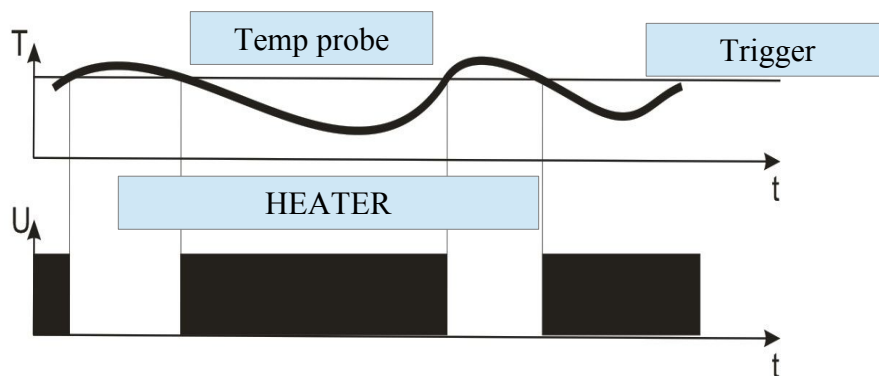

When it exceeds a set temperature distillation unit may stop heating. You will get a beep and the display will show the reason of alarm (number of probes). After lowering the temperature of the heater is engaged again.

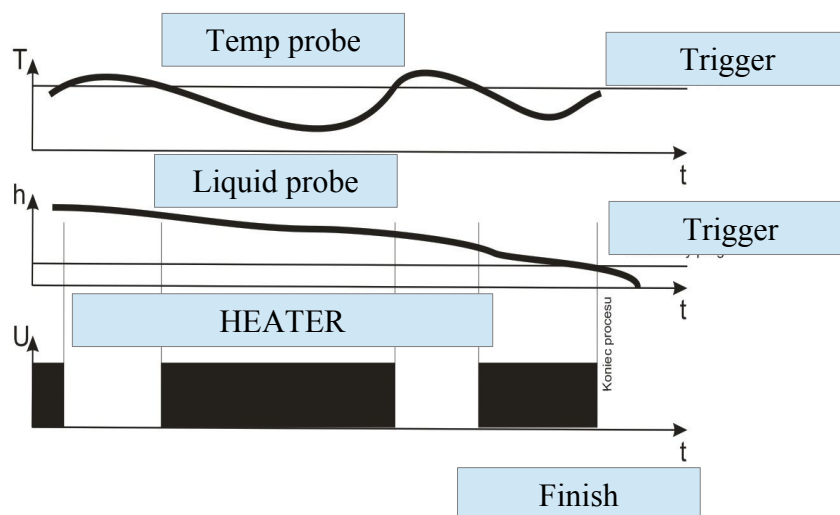

In the version with access to the solenoid, you can set the temperature at which it is to be triggered solenoid valve (adjustable hysteresis of 0.0 with an accuracy of 0.1 degree).

In the version of PRD3W you can set the temperature at which it is to be triggered a second solenoid valve (adjustable hysteresis of 0.0 with an accuracy of 0.1 degree).

In the version of the entry level sensor it is possible to stop the heating process when the sensor indicates the low level of the liquid.

Depending on the operating mode, the screen displays such as tank, head, column, cooler in the distillation mode and 1 respectively PROBE, PROBE 2 PROBE 3, 4 PROBE mode of smoking and brewing.

During distillation and smoking can rename temperature probes.

## SETTING THE TEMPERATURE ALARM

Use the "+" and "-" to select from a menu which they relate to the temperature setting.

Zbiornik	temp 000.0	
<b>Głowica</b>	<b>temp 000.0</b>	
Kolumna	temp 000.0	
Chłodnica	temp 000.0	
Moc grzałki	000%	
<<	OK.	>>

Confirm the choice by pressing "OK"

Window appears set alarm temperature.

Then the "+" "-" set the temperature level at which the alarm is to be sound. The setting and confirm with "OK".

Screen appears with a choice of whether the over-temperature safety is to be off the heater or not and at what temperature the heater is to be disconnected.

Temperature audible alarm on and off the heater are two different settings.

Information about an alarm is signaled by a beep (if the sounds are not excluded), and the appearance on the screen to notify the ALARM number of the probe.

To turn off the beeping siren, briefly hold the "OK" Information on the screen will disappear only after the cause of the alarm.

Zbiornik	temp 000.0	
Głowica	temp 000.0	
Kolumna	temp 000.0	
Chłodnica	temp 000.0	
Moc grzałki	000%	
<b>ALARM 3</b>		
<<	OK.	>>

Emergency shutdown of the heater is indicated by a flashing display of the heater power ..

Zbiornik	temp 000.0	
Głowica	temp 000.0	
Kolumna	temp 000.0	
Chłodnica	temp 000.0	
Moc grzałki	<b>000%</b>	
<<	OK.	>>

## Calibration of the temperature indicated

The user can calibrate the device with its own thermometer.

Use the "+" and "-" to select from the menu the temperature to be calibrated.

Zbiornik	temp 000.0	
<b>Głowica</b>	<b>temp 000.0</b>	
Kolumna	temp 000.0	
Chłodnica	temp 000.0	
Moc grzałki	000%	
<<	OK.	>>

Confirm the choice by pressing "OK"

Window appears set alarm temperature .

We press "OK"

Window appears temperature calibration .

Then the "+" "-" set the coefficient of linearity ( slope ) "B", which causes the indication  $T' = B * T$  The setting and confirm with "OK" .

Window appears the temperature calibration of the index A.

Then the "+" "-" set shifting "A" which will identify  $T' = A + B * T$ . The setting and confirm with "OK" .

It is recommended to leave the default  $B = 1.25$  and  $A = 0$

"B" to adjust the temperature with an increase in the difference of the temperature indication of the expected increases or decreases . For example, at room temperature, the temperature is underestimated by 0.1 degrees and 80 degrees with a 0.3 degree.

"A" to adjust when with increasing temperature difference from the expected temperature indication is constant. For example, the temperature in the whole range is underestimated by 2 degrees .

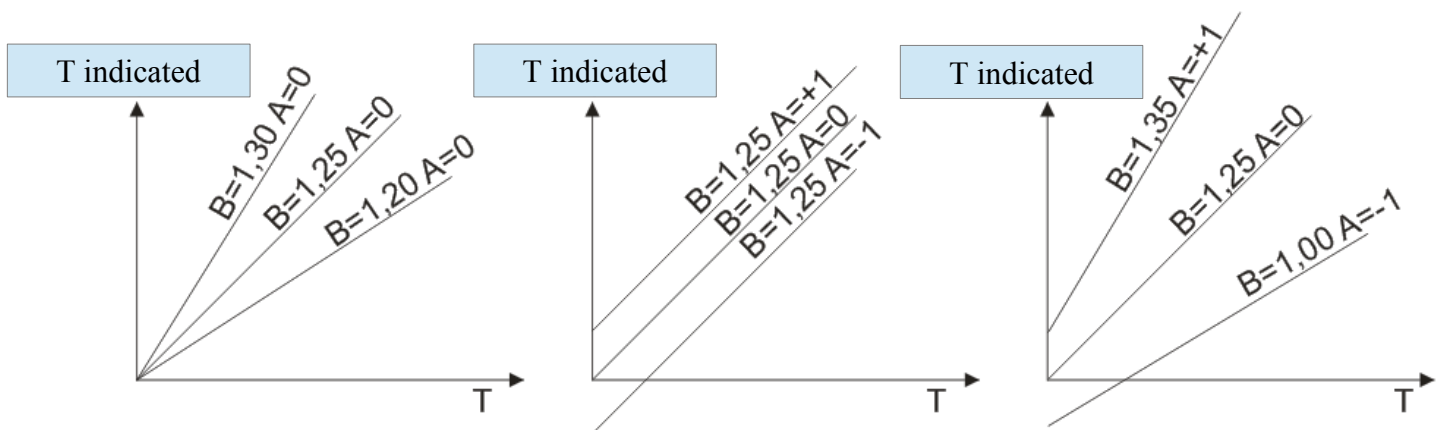

The unit is supplied pre-calibrated. If your thermometer shows 19 degrees does not mean that such a temperature prevails throughout the room. The difference in temperature mainly depends on the height and mounting location of the sensor, for example, there is a different temperature in a room closer to the radiator, the floor, the ceiling, element wooden, metal or by the window.

Analogous behavior of the temperature in the unit (the still smokehouse). The temperature can vary depending on the mounting location, method of installation, thermal conductivity, etc. That's why we left you can manually calibrate the probes.

Calibration of the probe is not necessary.

## SETTING PERFORMANCE SOLENOID (mode of distillation)

In the version with access to the solenoid, you can set the temperature at which it is to be triggered (off) solenoid.

PRD3W version you can set the temperature at which it is to be triggered (off) of the second solenoid.

The valve can operate in two modes: HYSTEREZE SCREEN or WINDOW 2

To change the mode of operation of the valve must enter the service menu and set the appropriate mode.

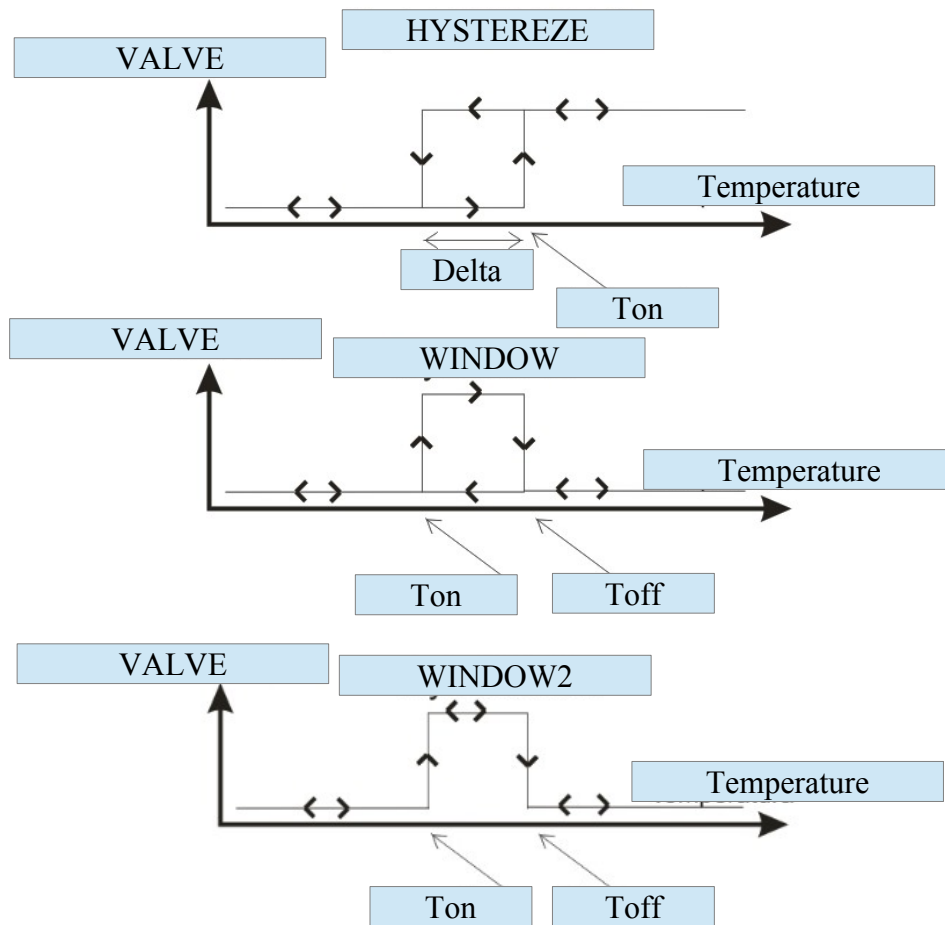

### HYSTEREZE mode

To set the temperature switch (off) valve must enter the service menu by holding down the "OK" when the power.

"OK" should go to the temperature setting. Press "+" "-" make the appropriate temperature setting and hysteresis action.

### WINDOW mode

To set the temperature switching valve must enter the service menu by holding down the "OK" when you turn on the power.

"OK" should go to the temperature setting switch. Press "+" "-" make the appropriate temperature setting.

"OK", go to the setting screen off temperature. Press "+" "-" make the appropriate temperature setting.

## WINDOW mode 2

To set the temperature switching valve must enter the service menu by holding down the "OK" when you turn on the power.

"OK" should go to the temperature setting switch. Press "+" "-" make the appropriate temperature setting. "OK", go to the setting screen off temperature. Press "+" "-" make the appropriate temperature setting.

The second way is pressing the "+" "-" to show the string SET VALVE. Then proceed as above.

The screen displays a VALVE 1 XXX YY, Y

XXX is the current state of the valve (switching ON or OFF off)

YY, Y is the current temperature probe control solenoid

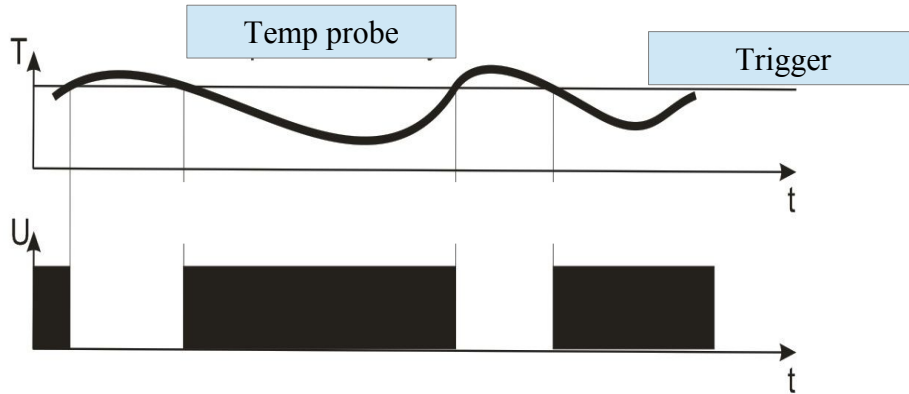

If the user selects in the service menu that temperature alarm is to end the process it can set an additional parameter which is the delay off valve.

With this function the temperature increases, eg in Kegs an alarm occurs. Alarm will complete the process and eg cooling apparatus will continue to operate for example for 5 minutes before cooling off occurs.

## SETTING POWER HEATER MANUAL MODE

Use the "+" and "-" to select the power of the heater.

```
Zbiornik temp 000.0
Głowica temp 000.0
Kolumna temp 000.0
Chłodnica temp 000.0
Moc grzałki 000%
<< OK. >>
```

Confirm the choice by pressing "OK"  
Setting window appears under the heater.

```
Moc grzałki
40%
<< OK. >>
```

Use the "+" and "-" to adjust.  
After confirming the "OK" button device returns to normal operation.

## SETTING THE AUTOMATIC ADJUSTMENT POWER

The device has the ability to automatically adjust power depending on the difference in temperature measured by the probe selected and set by the user.

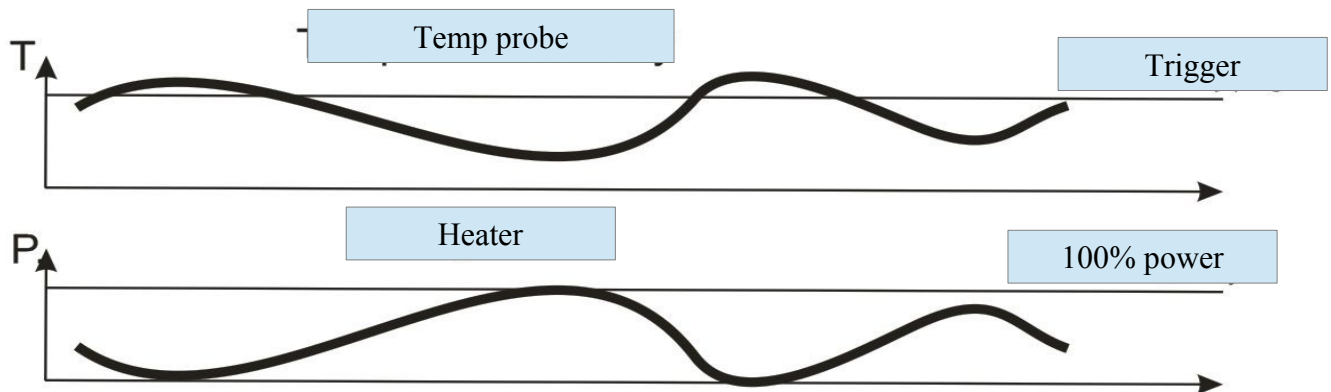

To set automatic mode, enter the service menu by holding down the "OK" when the power. When you see the string must quickly release the SET button.

"OK", go to the setting screen "mode Automatic heating". Press "+" "-" make the appropriate setting AUTO or MANUAL.

The user then proceeds to set the temperature to which the scorched heater.

Press "+" "-" make the appropriate settings.

The user then goes to the power control factor setting Y.

Press "+" "-" make the appropriate settings.

Where power is adjusted according to the formula  $P [\%] = Y * (T \text{ set} - T \text{ current})$ .

In MANUAL mode, the user can select the service menu or the attached device power is expected to be 0% if the driver is to be started from the last set power.

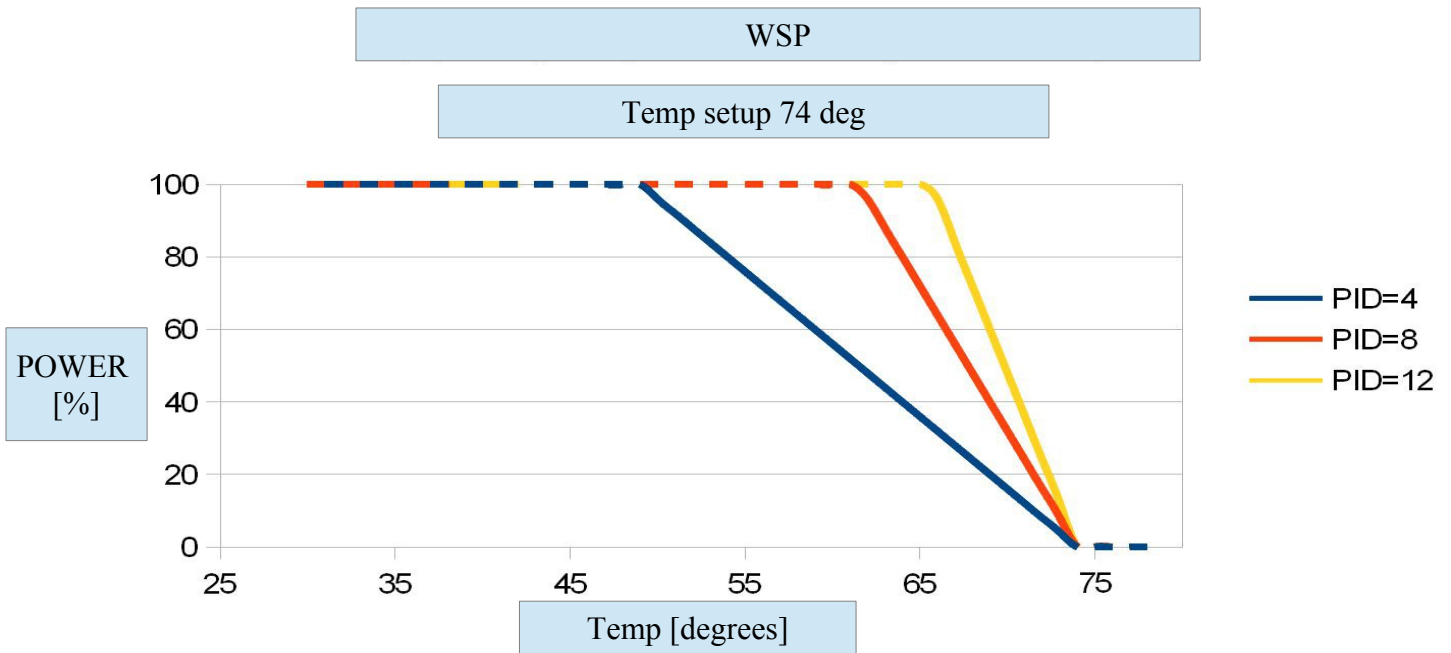

When you set the AUTO mode during normal operation by pressing the "+" "-" to highlight the inscription POWER HEATERS and as above, adjust power.

Taktualna distillation mode is the temperature of the selected probe.  
 During smoking Taktualna calculated is the average temperature of the probe selected by the user.

A new driver is the ability to set minimum power in automatic mode. To set the value you should enter the service menu and go to the parameter "Minimum power"  
 If its value is non-zero then the power is regulated in the following manner  
 Where power is adjusted according to the formula  $P [\%] = P_{min} + Y * (T_{set} - T_{aktualna})$ .  
 When the temperature reaches the set point then the system operates with minimal power set. When the temperature exceeds the power is decreased.

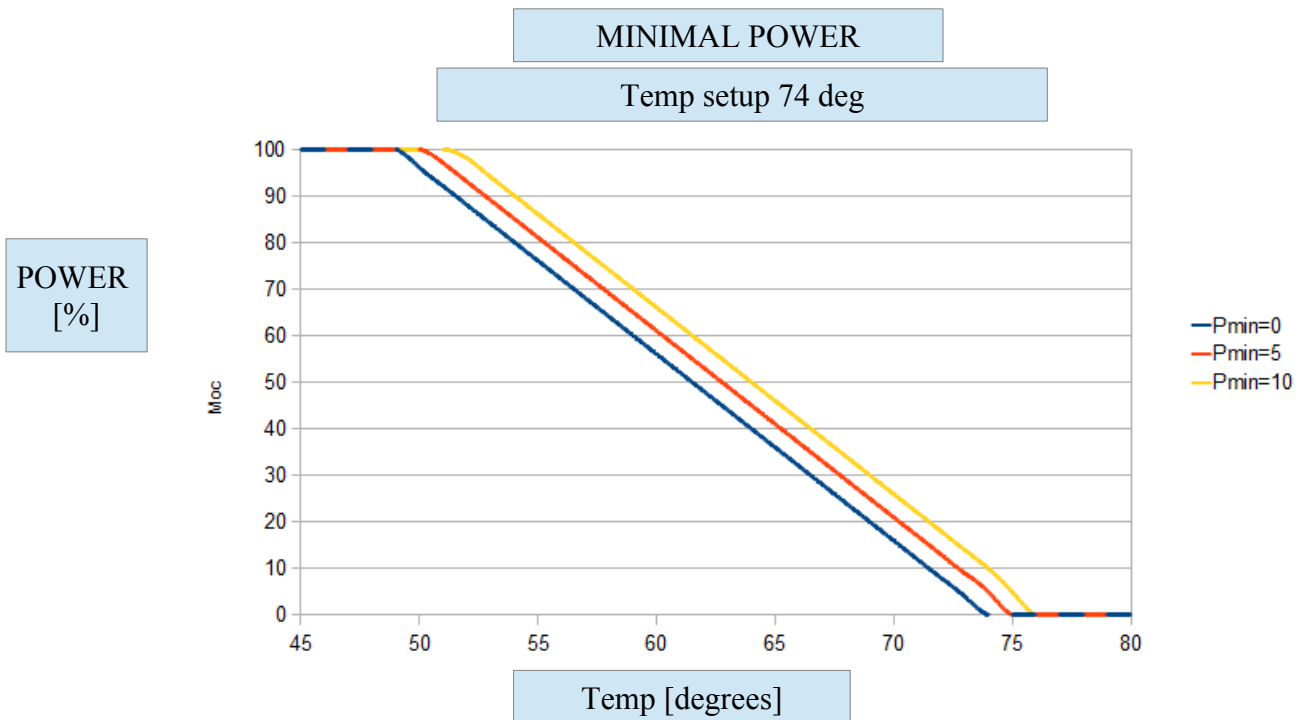

WSP ratio (simplified)

The higher the ratio, the smaller heater.

The smaller the larger the coefficient heater.

What smaller tank, the smaller ratio.

The bigger the tank the bigger factor.

If the driver can not keep up and the temperature is too low, often needs to be increased.

If the driver is a very controlled and the temperature often is too high it should be reduced.

Please remember to set the minimum power which is also affected by temperature. When it is too low, the temperature is too low. Otherwise vice versa.

## **SETTING MODE**

The device is ideally suited for both distillation and the making of smoking products.

To change the mode of operation, when turning on the power , press the Center button.

When you see the string must quickly release the SET button . After entering the menu, select the operating mode .

With the buttons you can move the entire cycle menu or wait for the controller after a few seconds returns to normal operating mode.

During smoking of the output is changed from the solenoid pump output smoke. PRD3W Series has an additional output of the fan. The fan switches in the second stage, the smoke pump switches in the third stage.

During the brewing device controls the heater according to the set temperature and brewing time .

In the service menu , you can activate the appearance of the selection window on startup . Please enter the service menu . After selecting SCREEN START - > SHOW SELECT after each startup occurs choice of mode : distillation , smoking, steaming .

## **SETTING YOUR NICK**

When commissioning the unit, hold the "OK" button. When you see the string SET should quickly let go of the button. One of the menu options is to set your own nickname.

Please click "OK" button until the device fails to set user name.

Use the "+" and "-" to select the desired character.

Choosing confirm "OK"

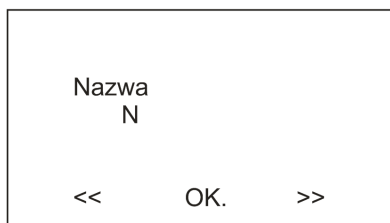

Use the "+" and "-" to select the next appropriate question.

Choosing confirm "OK"

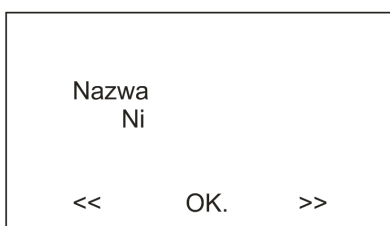

Action repeated eight times.

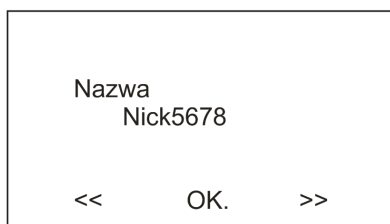

User Name has been set.

## **SETTING THE NAMES OF INDIVIDUAL PROBE**

When you start the device, hold the "OK" button. When you see the string must quickly release the SET button. One of the menu options is to set the names of the probes.

Please click "OK" button until the device fails to set the name of the probe.

Proceed as in the case of change of name of Nick (earlier point)

## TEMPERATURE CHARTS

Use the "+" and "-" to select Charts.  
Confirm the choice by pressing "OK"



"OK", go to the following graphs.

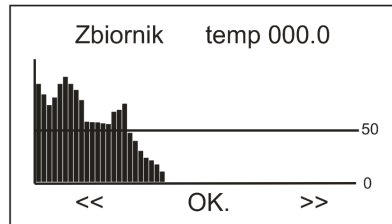

## ADJUSTMENT LCD

When you start the device, hold the "OK" button. When you see the string must quickly release the SET button. One of the menu options is to set the contrast of the display.  
Please click "OK" button until the device switches to adjust the contrast.  
Use the "+" and "-" to select the desired level of contrast.  
Choosing confirm "OK"

## **CHANGE THE ORDER OF THE PROBES**

The operation performed when the probes are mounted on the device and you can not replace physical probes such as after replacing the probe.

The probes are connected in parallel and the numbers are distinguished manufacturer MAC

.  
When you set up the service menu " Sensor 0 " to 0 " sensor 1" to 1 so that after resetting the controller will sort them ascending by MAC addresses.

After running the display , eg

head 20.0

Column 20.0

tank 20.0

Cooler 20.0 ( or ARC )

If you hold the probe and changes to the first temperature probe is marked as 0

If you hold the probe and changes to the second temperature probe is marked as 1

If you hold the probe and changing the third temperature probe is marked as 2

If you hold the probe and varies fourth temperature probe is marked as 3

Then write on a piece that you want to receive :

SONDA1 probe 2

SONDA2 probe 1

SONDA3 probe 0

SONDA4 probe 3

Then, in the service menu set

Sensor 0 set 2

Sensor 1 set 1

Sensor 2 set 0

Sensor 3 set 3

## **ADJUSTABLE FEATURES MENU SERVICE**

To enter the service mode during power press the Center button.

When you see the string must quickly release the SET button. After entering the menu, select the operating mode.

With the buttons you can move the entire cycle menu or wait for the controller after a few seconds returns to normal operating mode.

## **DESCRIPTION OF SERVICE SETTINGS MENU**

Settings

Set ( to go to other settings )

Reset ( sets the default settings )

Application:

smokehouse

distillation

brew

Startup Screen :

Show selection ( to select the operation mode after each attached)

Skip choice ( hides select the operation mode , the device operates according to the last selected mode )

power window

YES ( when entering the power setting window appears election mode MANUAL / PID )

NO ( when going into power settings immediately proceeds to the parameters)

The alarm function

Off heating ( temperature exceeding the alarm turns off the heater )

Ends the process ( temperature exceeding alarm to complete the procedure )

Off Delay Output

Time in seconds ( the time until the process are off valves )

sound

so

not

Thu . liquid level

Yes ( liquid level sensor is used )

No ( liquid level sensor device is used )

sensor Type

OFF / ON (NC )

ON / OFF (NO)

Name:  
Written string that is displayed when you start

Name 1 :  
Written string displayed as the description sondy1 distillation mode

Name 2:  
Written string displayed as the description sondy2 distillation mode

Name 3 :  
Written string displayed as the description sondy3 distillation mode

4 Name :  
Written string displayed as the description sondy4 distillation mode

Name 1W :  
Written string displayed as the description sondy1 mode of smoking

Name 2W :  
Written string displayed as the description sondy2 mode of smoking

3W Name :  
Written string displayed as the description sondy3 mode of smoking

Name 4W :  
Written string displayed as the description sondy4 mode of smoking

Autogrzanania mode :  
AUTO ( heating power automatically set PID)  
MANUAL ( heating power set manually ) NO ( manual adjustment )

Temperature auto  
The temperature to which is to aim heater in the auto adjustment mode

coefficient of auto  
Factor accumulation of power in automatic mode (described in the manual)

Number of PID probe

No probe which is to be taken to control the signal power in automatic mode. Number corresponds to the order they appear on the screen.

PROBE 1

PROBE 2

PROBE 3

PROBE 4

news  
Set to NO

Solenoid 1  
Yes ( the device has a valve control output 1 )  
No ( the device does not have a valve control output 1 )

#### Valve type 1

OFF / ON (display OFF when the temp <ustawionej, ON when temp> set )

ON / OFF (display ON when the temp <ustawionej, OFF when temp> set )

#### Mode of operation of the valve 1

HYSTEREZE

WINDOW

WINDOW 2

#### Switching solenoid 1

Set the temperature switch solenoid .

Turn off solenoid 1

Set the temperature off solenoid ( WINDOW mode ) .

#### Hysteresis solenoid 1

Set the hysteresis switching min 0.0 ( 0.1 default mode HYSTEREZE )

#### Solenoid valve No. 1 :

No probe which is to be taken to control the solenoid signal . Number corresponds to the order they appear on the screen.

PROBE 1

PROBE 2

PROBE 3

PROBE 4

#### delay Valve 1

Set the delay after which the valve off at the end of the distillation process as a result of rising temperatures , eg in Kegú . This function works when a user selects the service menu that has a temperature alarm complete the process.

#### Solenoid 2

Yes (the device has an output control valve 2 )

No ( the device does not have a valve control output 2 )

#### Valve type 2

OFF / ON (display OFF when the temp <ustawionej, ON when temp> set )

ON / OFF (display ON when the temp <ustawionej, OFF when temp> set )

#### Mode of operation of the valve 2

HYSTEREZE

WINDOW

OKNO2

#### Switching solenoid 2

Set the temperature switching solenoid 2

#### Turn off solenoid 2

Set the temperature off solenoid 2 ( WINDOW mode ) .

#### Hysteresis solenoid 2

Set the hysteresis switching min 0.0 ( 0.1 default mode HYSTEREZE )

Solenoid valve No. 2:

No probe which is to be taken to control the solenoid signal . Number corresponds to the order they appear on the screen.

PROBE 1  
PROBE 2  
PROBE 3  
PROBE 4

delay zaworu2

Set the delay after which the valve off at the end of the distillation process as a result of rising temperatures , eg in Kegú . This function works when a user selects the service menu that has a temperature alarm complete the process.

Solenoid 3

Yes (the device has an output control valve 3 )

No ( the device does not have a valve control output 3 )

Valve type 3

OFF / ON (display OFF when the temp <ustawionej, ON when temp> set )

ON / OFF (display ON when the temp <ustawionej, OFF when temp> set )

Mode of operation of the valve 3

HYSTEREZE

WINDOW

WINDOW 2

Switching solenoid 3

Set the temperature switch solenoid 3

Turn off solenoid 3

Set the temperature off solenoid 3 ( WINDOW mode ) .

Hysteresis solenoid 3

Set the hysteresis switching min 0.0 ( 0.1 default mode HYSTEREZE )

Solenoid valve No. 3:

No probe which is to be taken to control the solenoid signal . Number corresponds to the order they appear on the screen.

PROBE 1  
PROBE 2  
PROBE 3  
PROBE 4

sensor 0

The choice of probe to be displayed as the first or SONDA1

sensor 1

The choice of probe to be displayed as a second or SONDA2

sensor 2

The choice of probe to be displayed as the third or SONDA3

sensor 3

The choice of probe to be displayed as the fourth or SONDA4

sensor 4

Set 4

## **SPECIFICATIONS**

Voltage: 230V +10% -20 % , 50Hz ( 3x230V , 3x400V in version 3 phases )

Operating temperature : -10 to +60 ° C

Temperature probes : +5 to +120 ° C

Heating output capacity : 5.5 kW single-phase version 3x5, 5 kW three-phase version

Load Output 1 ( valve / pump ) : 100W 230V

Output load 2 ( PRD3W ) : 100W 230V

Maximum Power Consumption : 4W

Resolution power control 0.25 %

Hysteresis solenoid 0.0-10.0 ° C ( 0.1 ° C resolution )

Standard probe length 1.8 meters

The maximum length of 6 meters probes

Housing: self-extinguishing

Degree of protection : IP20

Warranty: 30 months from the date of sale ( in Poland ) 12 months beyond

Compliance with standards: EN 60529

Thermal protection : YES

Cooling: Built-in fan

The product does not contain lead (Pb - Free)

## LAYOUT

### PRD3W+, PRD3W DUO

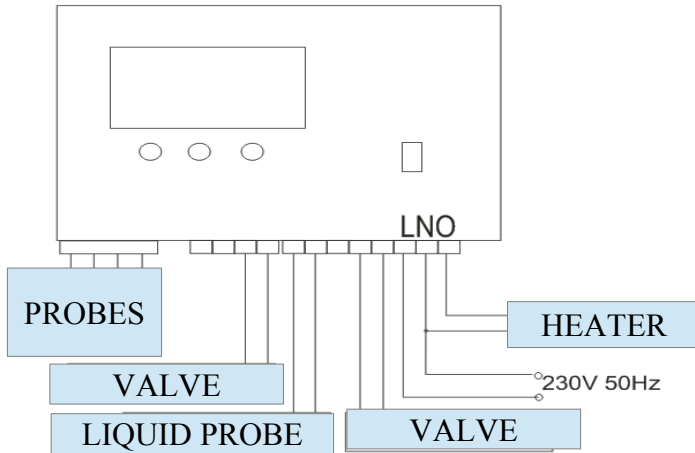

**PLEASE DO NOT BE SHOWN SUGGEST**

### DESCRIPTION OF CONNECTORS PRD3W + (rear view)

NOTE!

LEVEL SENSOR WORKS ON AN short-circuiting. INPUT TERMINALS WHEN DO NOT HAVE CONNECTIONS (opening) THIS MEANS NO LIQUIDS

DEPENDING ON THE TYPE OF VALVE CLOSED, OPEN  
PLACE THE TYPE OF SERVICE MENU

TRANSPARENT COVERS ARE AN INTEGRAL PART OF THE EQUIPMENT.  
DO NOT USE THE DEVICE WITHOUT GUARDS

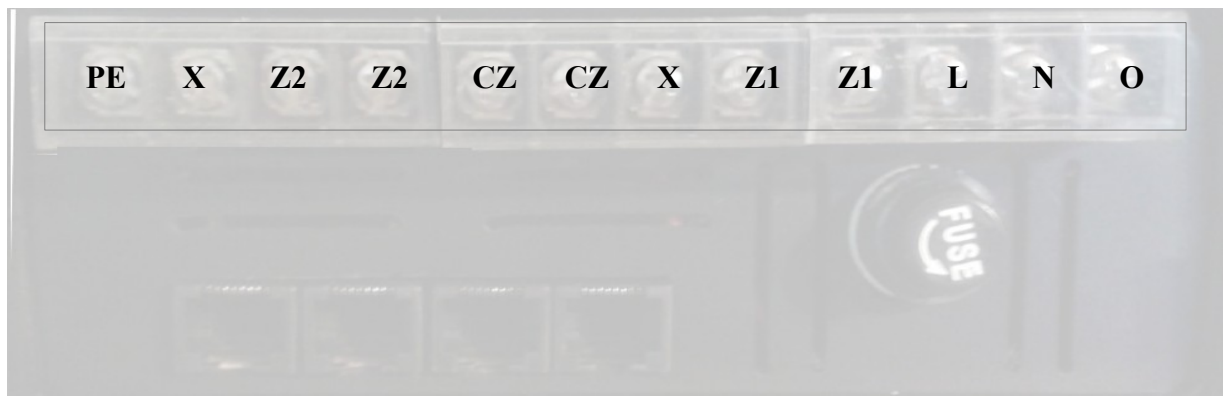

**PRD3F**

N	L1	L2	L3	PE	N	O1	O2	O3
---	----	----	----	----	---	----	----	----

**DESCRIPTION OF CONNECTIONS PRD3F(3fases)**

## PRD3(W)+ with wires

### DESCRIPTION OF CONNECTORS PRD3 (W) + (with wires)

(valve2)	(valve2)	valve1	Zvalve1
----------	----------	--------	---------

### PLEASE DO NOT BE SHOWN SUGGEST

### DESCRIPTION OF CONNECTORS PRD3 + (rear view)

NOTE!

LEVEL SENSOR WORKS ON AN short-circuiting. INPUT TERMINALS WHEN DO NOT HAVE CONNECTIONS (opening) THIS MEANS NO LIQUIDS

DEPENDING ON THE TYPE OF VALVE CLOSED, OPEN PLACE THE TYPE OF SERVICE MENU

TRANSPARENT COVERS ARE AN INTEGRAL PART OF THE EQUIPMENT.

**DO NOT USE THE DEVICE WITHOUT GUARDS**ĄDZENIA .  
ZABRONIONE JEST UŻYWANIE BEZ OSŁON

## **STRANGE SYMPTOMS OF EQUIPMENT-TIPS BEFORE YOU CALL**

Symptoms	Tips
You can not adjust the power	Check if mode is set to automatic power control. Check the settings and there is no preset potentiometer function.
The display does not light	Check the fuse Toggle switch located next to the LCD display
The device does not heat, is warm	Check the vents.
The tank does not reach the proper temperature	In auto mode, increase the power factor of the heater Y. In manual mode, set heater power increase. Replace the heater on the heater with a higher power. Check-mode (smoking, distillation, brewing).
The heater is not working properly	The heater is not working properly Check if mode is set to automatic power control. Check whether a given sensor have set off the heater. Possible damage to the output. Check-mode (smoking, distillation). Measurement of no-load voltmeter is incorrect because the output system to work properly requires a minimum of a few watt load.
Fading light	Dim the lights due to overload the electrical system. Each 2kW heater power is a current of up to 5A at the old installation or thin wires can cause voltage drops. Please check the fuses in the house.
The controller displays other than the actual temperature	Calibrate the probe.
The controller displays other than the actual temperature 000	Reset the unit. The probes are detected immediately after the power is turned on. Connection during operation will not detect it. If the problem persists it means damage to the probe or cable. You can connect to one poll and see which is faulty.
The device is a strange black knob	It is a fuse. If there is blown, do not touch it.
The device displays a reverse valve status ON and OFF	Enter the service menu. Change the "type valve" for ON / OFF or OFF / ON
On display shows LOW, no heating	Low liquid level alarm (when the sensor is connected) If there is no sensor should be connected to each other two terminals SENSOR (wiring

	<p>diagram) or select the service menu no sensor.</p>
Wrong sequence of measured temperatures	<p>The probes are connected in parallel and the numbers are distinguished manufacturer MAC. When you set up the service menu "Sensor 0" to 0 "sensor 1" to 1 so that after resetting the controller sorts them by increasing MAC addresses. The user can change the order in the service menu.</p>
The controller is unstable, alternately heats and reheats in automatic mode PID	<p>In the service menu reduce the coefficient of PID control.</p>
The valve works vice versa	<p>Replace one of the wires of the valve to T &lt;TARC or T&gt; TARC or replace the service menu parameter ON / OFF or OFF / ON of the valve</p>
The device does not save power.	<p>In the service menu the user can choose whether or not to store the power set if you want a setting of 0% power.</p>
Controls the device correctly in the machine.	<p>Verify that the correct number is set to probe power control. When properly selected number warming such as hair will change the power. If not, change the number and check again.</p>
The driver is very hot, the lack of control.	<p>The unit has a maximum power limit. Electric heaters are manufactured with different tolerance eg 10 or even 20%. This means that such heaters with a total power of 3.5 kW can charge the device with power almost 4kW (at 10% tolerance). If heaters are not investigated that charge a max 3,5 kW, use a power supply.</p>
The driver is warm	<p>The device is working properly. Most amplifiers, televisions, cell phone chargers is warm. The device has thermal protection. If the temperature is too high, the controller automatically switches off the control.</p>
Constant voltage on output (of power or valve).	<p>Unfortunately it is caused by inattention during connection or liquid spill.</p> <p>Driver outputs are at least twice bigger. It means that "plus" output has BTA41 triacs that are predicted for 40 AMPERES.</p> <p>Additionally outputs have galvanic isolation, and a triac foot has ONLY CONTACT you're your heater. It means that output circle in electric way reminds contactor.</p> <p>If you don't believe us, you can go to entrusted electronics service and ask about analogical situation with connecting speakers to amplifier, 99,99999% is caused by bad use of output and not by device.</p> <p>Repairs of such devices are due (flat rate 6 EUR + cost of componentry)</p>

## PORTS OF PROBE

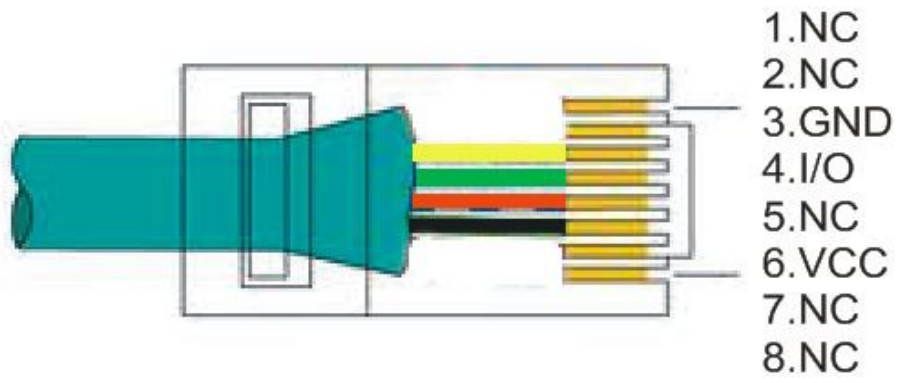

## **FIRST TIME SETUP.**

1. 1 Connect the power cord according to the diagram (2 and 3 pin from the right) .
2. 2.Connect heater (1 and 2, the second pin from the right) .
3. 3.Connect wires from the valves. Pay attention to the supply voltage ( 12V or 230V) or use a snap PPE .
4. 4.If want to use a liquid level sensor should plug it in accordance with the scheme . If you do not then you should short the two pins with the cable or turn off the service menu ( SENSOR LEVEL -> NO). Otherwise, the screen shows LOW and the output power will be disabled.
5. 5 Connect the sensors .
6. 6 Turn on the power switch switch in position 1
7. 7 Check that the screen appears DETECTED : 4 where 4 is the number of probes.
8. 8 Wait for the system.
9. 9.Sprawdzić and after about 15 seconds, seconds, appear to indicate a temperature
10. Hold one probe 10 .
11. 11 Observe that the temperature change.
12. 12 Mark down the name of the probe as intended
13. 13 Repeat this process for all probes
14. 14 Turn off the power
15. 15 Press the Center button turn on the power .
16. 16 In the service menu to set the parameters ( mode of operation , the number of probe PID , proper name of the probe , minimum power , maximum valve performance , particularly the numbers of probes control valves , etc. )
17. 17 After passing the service menu to reset the controller .
18. 18 Press + to highlight the first line .
19. 19 Set the desired parameters of power.
20. 20 Exit to the main screen
21. 21 If the work is in automatic mode, heat gently probe which has the power to control and check whether changing displays the current power . + Click to highlight the first line . Set the temperature of the car for about 78.4 degrees. Exit to the main menu .
22. 22 Press the + highlight SET VALVE, adjust the settings according to the needs of the valves , it is suggested to set the temperature around 30 degrees
23. 23 Exit to the main menu .
24. 24 Check the operation of the valve by heating selected probe
25. 25 If you set the temperature lower to enter the submenu VALVE SET and set the correct operating temperature valves.
26. 26 The device is pre- configured.

## Dear User,

In the beginning we want to thank you for choosing PAMEL. We are certain that you will be pleased with this choice. We design device in way that fulfill yours requirements and guarantees future trouble-free use.

**Before start of using of device please became acquainted with montage procedures and conditions of exploitation described in Manual. In case of any questions please contact us.**

**791-607-644 (OFFICE 9 A.M. – 2 P.M., weekday)  
609-703-931 (SUPPORT 4 P.M. – 9 P.M., whole week)**

## **WARRANTY CONDITIONS**

- 1. PAMEL makes warranty on area of Republic of Poland for period of 60 months starting on date of beginning warranty period, but no longer than 80 months from production date placed on product that is under warranty under condition of use of device according with its destination and technical-exploitation conditions described in Manual.**
2. Warranty does not cover movable equipment elements (accessories) design for self-assembly by user e.g. aerials, sensors, handles, heaters, cables or power batteries.
3. Guarantor is obligated to free removal of physical faults if these faults occur during warranty or to deliver faults-free equipment if in warranty period at least 4 repairs of equipment were made, and equipment remains faulty. In case of exchange, product will be exchanged for new one of the same model or of close, not worse technical parameters. If such exchange won't be possible, then Customer gets refund.
3. Warranty period described in paragraph 1 is extended by time of repair.
4. Time of repair is counted from the day of device submittal to service point to day of issuing device to shipper in order to handover it to Buyer.
- 5. In case of fault occurrence Buyer reports this fact to Guarantor via e-mail ([pamel@pamel.pl](mailto:pamel@pamel.pl)) or via phone, then Guarantor tries to solve this problem remotely and point further route of complaint proceeding.**
6. On request of Guarantor Buyer is obligated to honest impletion of Complaint Protocol given by Guarantor.
7. Guarantor is responsible only for faults resulting from causes in sales subject.
8. Warranty don't covers damages resulting from improper use, particularly from storing and maintenance incompatible with exploitation destination, use of improper exploitation materials, own repairs of upgrades, mechanical damages resulting from fault of user, exterior causes like contamination, inundation, steam condensation, atmospheric phenomena, random events. Warranty also doesn't cover damages of electronic subsystems resulting from crossing rated parameters.
9. Warranty doesn't cover claims in respect of technical parameters if they are consistent with ones given by manufacturer.
- 10. Condition of maintaining warranty permissions by Buyer is provision of device to service point stated in paragraph 5 in complete state in packet that decreases risk of its damage together with documentation, wires and other elements provided according to realization of agreement without violated seals or labels together with warranty card.**
11. Warranty don't covers materials and actions belonging to regular exploitation like montage of equipment, programming, cleaning, maintenance, replacing bulbs and fuses, operation control. Services mentioned above are due. In case of unfounded complaint (complaint of working device or of damage caused by user) complainer will be charged for expertise and transportation.
12. Service point except situation mentioned in paragraphs 7-11 can refuse warranty repair in following situations:
  - if data in documentation varies from device data,
  - annotations in documents made by unauthorized persons.
13. Physical faults revealed during warranty period will be removed during 21 days, counted from the day following the day of submittal device to service point. In case of necessity of importing parts from abroad Guarantor reserves rights to extend warranty period for time needed for repair and each time will inform Customer about such situation via e-mail.
14. Device should be mounted according to required standards and technical requirements encapsulated in

- manual. If it is regulated by law, then device need to be mounted by person with relevant permission.
15. Right and responsibilities of parties under warranty are regulated only by provisions in this document.
16. Equipment uncollected from service during 3 months from the end of repair becomes service property.
17. In situation where warranty repair requires parts exchanged element becomes property of Guarantor.
18. Guarantor holds no responsibility for damages caused by loss of user data saved in device, we also inform that device will be returned in production state.
19. **Buyer by signing declares that is acquainted with warranty conditions and accepts them. Warranty card without Buyer's sign will be considered invalid.**

**WARNING!**

Number of repairs does not include particularly: cleaning, maintenance, bulb, filament or fuse exchange, repairs resulting from exploitation wear, e.g. wear of potentiometers, etc.

START OF WARRANTY PERIOD	DEALER STAMP	CUSTOMER SIGNATURE