



42-300 Myszków, 5E Urodna Street

UNIVERSAL CONTROLLER
POWER AND TEMPERATURE



[T WOULD PRD2

Zeskanuj!



PRD2



PRD2F

**PAMEL ONLY MANUFACTURES CONTROLLERS,
WE DO NOT SELL KEG KITS**

**PLEASE READ THE MANUAL
DON'T YOU KNOW? CALL US! WE DON'T BITE
453-343-360 (OFFICE 9-14 weekdays)
453-343-360 (Technical Support 16-19 Monday-Saturday)
www.pamel.pl pamel@pamel.pl**



https://www.youtube.com/@PAMEL_STEROWNIKI/

Table of contents

INTENDED USE	4
HOW IT WORKS	5
SETTINGS MENU	7
FIRST TIME COMMISSIONING.....	9
POWER FACTOR CALIBRATION AND ADJUSTMENT	10
TECHNICAL PARAMETERS	11
CONNECTION DIAGRAM.....	12
BEFORE YOU CALL.....	13
ADDITIONAL OPTIONS	17
Remote alarm module.	17
Power cords.	17
Device configurations due to cable leads (connectors).....	17
TERMS AND CONDITIONS OF THE WARRANTY.....	23







Before connecting and using the appliance, please read this user manual carefully.

If you have any problems understanding its contents, please contact the seller of the device. Self-assembly and commissioning of the device is possible provided that the installer has basic knowledge. However, it is recommended that the device be installed by qualified personnel.

The manufacturer is not responsible for damage that may result from improper installation or operation of the device. Making repairs and modifications yourself will void the warranty.

The manufacturer reserves the right to change the appearance, features, functions and technical parameters of the device in order to improve the quality of the product.

The photographs, drawings and texts used in this manual are the property of PAMEL.

	<p>Do not disassemble or introduce modifications.</p> <ul style="list-style-type: none"> • This may cause a malfunction • Contact if necessary authorized service <p>We don't bite. It will be cheaper than repairing or altering it yourself</p>
	<p>If the appliance will not be used for a long period of time, disconnect the power supply. If you want to carry out electrical work, e.g. changing wires, disconnect the power supply.</p> <p>It is forbidden to leave the operating appliance unattended.</p>
	<p>Avoid routing the power cable through the places through which they pass people.</p> <ul style="list-style-type: none"> • Someone can catch on the cable and drop the device, causing damage to it or injuring the operator.
	<p>Do not touch the device with wet hands.</p> <ul style="list-style-type: none"> • Possibility of electric shock
	<p>Do not use the device where it may be exposed to liquids.</p> <ul style="list-style-type: none"> • Short circuit or shock may occur electric current.
	<p>Do not place the device firmly in places dusty.</p> <ul style="list-style-type: none"> • There is a risk of poor cooling of the device and the operation of thermals. <p>No one likes dirt, especially fans.</p>

PRD2 SERIES UNIVERSAL POWER AND TEMPERATURE CONTROLLER

INTENDED USE

The PRD2 is used to regulate the power of the heating elements. Depending on the device version, the maximum adjustable power is:

- 4.5 kW – for the PRD2 version,
- 3 × 4.5 kW – for the PRD2F version.

The device is designed to control **resistive loads**, such as electric heaters.

Do not use it to adjust induction or lighting circuits.

An additional advantage of the device is the possibility of expanding its functionality. The user can **purchase temperature probes** at any time, thus increasing the capabilities of the controller and adapting it to more advanced applications.

In the event of a change in the ambient temperature of the controller, the set or the tank is flooded with liquid, it is necessary to wait to eliminate the phenomenon of condensate causing damage to the power amplifier due to a short circuit caused by condensation, e.g. on the heater.

The maximum output power for the controller is assumed for 230V. In the event of increased voltage in the grid (e.g. power transformer or photovoltaics), the maximum load should be avoided as the load power of the consumer may increase by 30%.

In winter, many damages are caused by condensation, in summer by an increase in voltage in the network.

Attention should be paid to the arrangement of the cables. The power cables of the controller and the heater must not be rolled into small loops. This creates a coil that can damage the driver or melt the wires.

HOW IT WORKS

Without connected probes, the device acts as a **power regulator**, without a temperature measurement function. In this mode, the user can smoothly adjust the power supplied to the heaters and thus indirectly influence the process temperature as well. A big advantage of the device is **the high power regulation resolution of 0.25%**, which allows you to select the heating level very precisely.

By connecting at least one probe, the device gains additional temperature control capabilities. In **MANUAL** mode, the user can adjust, using two buttons:

- power supplied to the heating circuit,
- the temperature to which the system is to aspire,
- maximum temperature, the achievement of which disconnects the heater control.

The currently set power and temperature values are displayed on the LCD screen in real time.

In the event of a power failure, the device **remembers the set power and temperature values**, so that after restarting it it is possible to continue working with the last saved settings.

Changing the settings is done by touching the fields:

- "+",
- "-".

Switching between screens:

- **power**,
- **temperature**,
- **alarm temperature** This

It is done by **briefly touching the center field** while the device is operating.

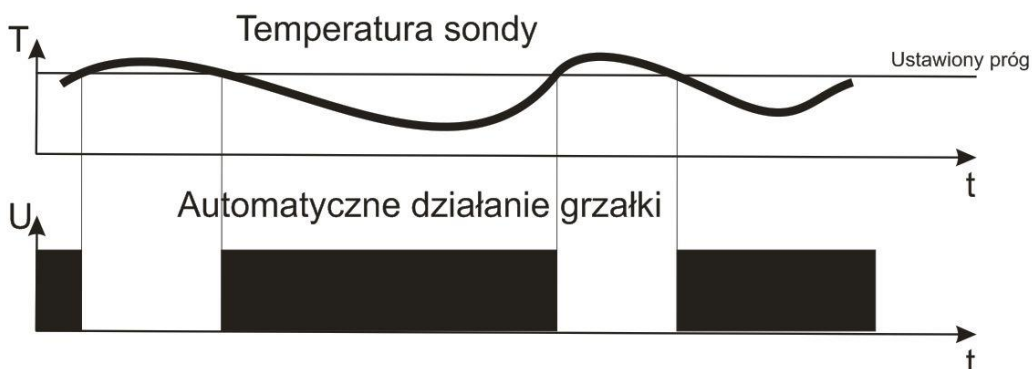

In AUTO P mode (recommended), the user can adjust the power supplied to the circuit and the temperature to which the system should aspire or the maximum disconnecting heater control. The power is automatically selected

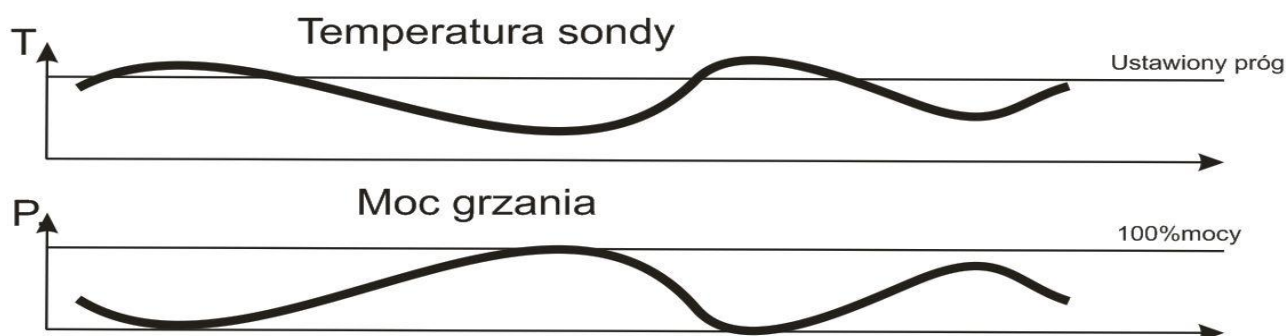

depending on the temperature difference: current and expected. By adjusting the WSP parameter, it can adjust the power factor per temperature difference. When underheating occurs, the coefficient should be increased. When overheating occurs, reduce.

Where power is adjusted according to the formula $P[\%]=WSP*(T_{set}-T_{current})/4$.

In AUTO PID mode, the user can adjust the power supplied to the circuit and the temperature to which the system should strive or the maximum disconnecting heater control. The power is selected automatically according to the PID algorithm.

A second temperature probe **can be connected to the device**. In addition to measuring an additional point, this temperature can also serve as **a stoppage for the device** when the set alarm value is reached.

This solution is particularly useful in processes where the temperature of the product or tank must be controlled in addition to the control temperature.

Examples of applications:

- **during smoking** , a second probe can be placed in the meat, and the process can be completed when the set temperature is reached, for example, $T_a = 50^{\circ}\text{C}$,
- **during distillation**, a second probe can be placed in a **KEG** or tank, and the process can end when a certain temperature is exceeded, for example, $T_a = 90^{\circ}\text{C}$.

This allows the device not only to regulate the course of the process, but also to automatically stop its operation when the selected temperature

condition is reached. This increases the convenience of operation, work safety and repeatability of the process.

To resume work, tap the middle button, which will turn off the alarm. The device reacts only after 30 seconds of exceeding the temperature "Ta", which gives time to change this temperature.

For better stability, the user can choose the minimum power Pmin, which is added to the calculated PID power. This will cause that when the desired temperature is reached, the heating will remain at the level of, for example, 5% and will not interrupt the heating.

In automatic mode, manual power change is not possible.

A short press of the middle button jumps to the next temperature setpoint.

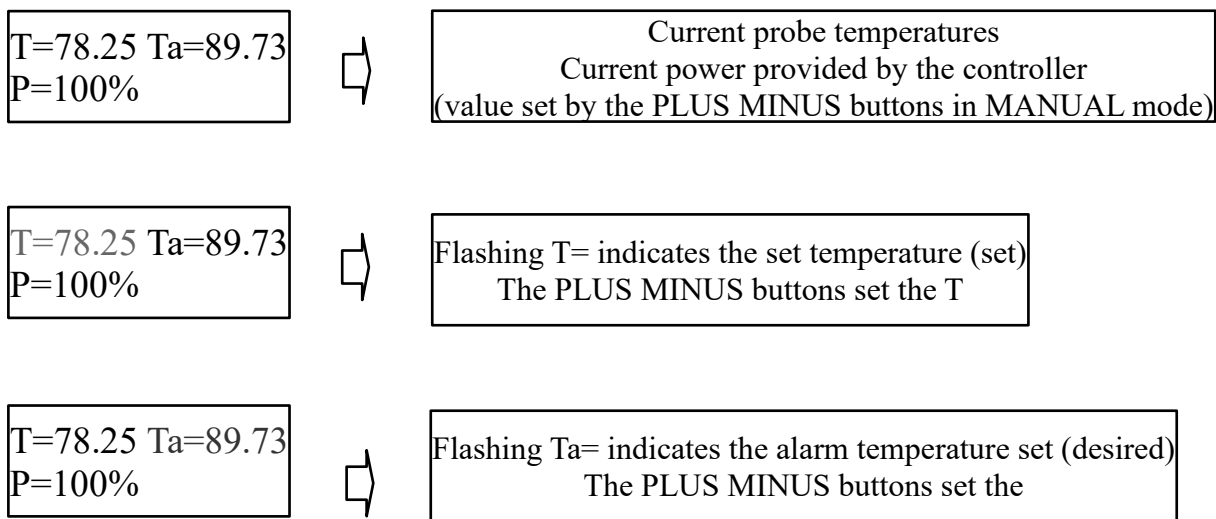

To enter the advanced settings menu, hold down the middle button for at least 5 seconds.

SETTINGS MENU

To enter the settings menu, hold down the middle button for a long time. Short changes the preview windows.

Then the minimum power of P_{min} is adjusted

Minimum power means the power provided by the controller when the expected temperature is reached.

In some cases, turning off the power completely can cause destabilization. The minimum power can be compared to the idle speed of a car engine. On average, it takes a value of about 10-20%

$P_{min}=17.00\%$

Then the maximum power P_{max} is adjusted

It is applicable in the case of installations with smaller fuses than those resulting from the power of the heaters.

In this way, we can artificially limit the maximum consumption of heaters, e.g. from 5 to 4kW

You don't have a need, leave a value of 100%

$P_{max}=100.00\%$

Another parameter is the MANUAL/PID control mode

Means proper manual and automatic temperature control.

UST MODE
AUTO P (RECOMMENDED)

UST MODE
MANUAL

UST MODE
AUTO PID

The next parameter is whether the controller should set the last power stored before turning it off, or start with a power of 0. This is used in manual mode when, for example, someone is working with a constant power, e.g. 30%

REMEMBER THE POWER
YES

REMEMBER THE POWER
NO

You can then swap the order of the probes. The probes are detected independently of the socket. The ordering depends on the serial numbers of the sensors. They can be converted by software by changing the parameter of the probe order or physically by manual to laying in another measuring point (not a socket)

ROUND SURVEY
0

Then the WSP power factor is adjusted (in AUTO P mode)

The coefficient means how strongly the controller should react to a change in temperature. Too small causes underheating, too much overheating.

The higher the capacity-to-power ratio, the higher the ratio. Don't overdo it. WSP=20 is quite enough. Higher values are for specific conditions. Best set to 12

WSP=12.00

Then the calibration factor B is adjusted.

$T_{\text{displayed}} = B * T_{\text{read from sensor}} + A$

Caliber B=1.28

Next, the calibration factor A is adjusted.

$$T_{\text{displayed}} = B * T_{\text{read from sensor}} + A$$

Caliber A=0.00

FIRST TIME COMMISSIONING

ATTENTION!

We suggest that the first start-up be carried out on water or an empty chamber.

Launch order

1. Connecting the deviceThe device must be connected according to the electrical diagram:

- power supply for **L** and **N** terminals,
- heater for **N** and **O** terminals.

2. Connecting the ProbesNeed to connect the temperature probes if they are used in your configuration.

3. Turning on the powerOnce the connections have been made, the power of the device can be switched on.

4. Identification of the function of the probesIn the case of working with two probes, it is necessary to determine which probe is responsible for power regulation and which is responsible for the alarm function.

The easiest way to do this is to gently warm one of the probes, for example with the warmth of your hand, and observe which temperature changes on the display.

Typical functions of the probes:

- **T** – temperature controlling the power of the device, e.g. **column** or **chamber**,
- **This** – the alarm temperature, e.g. **tank**, **KEG** or **cold cut**.

If the probe is needed, you can:

- **switch places physically**,
- or change their assignment in the device settings using the **KOL PROBD** parameter.

5. Mounting the probes in the systemOnce the function of the probes has been recognized, they should be fixed in the appropriate places of the apparatus, for example in the smokehouse or distiller.

6. Setting the operating modeYou should touch and hold the middle button for a long time to enter the **service menu**. In the menu, you need to set the appropriate mode of operation:

- **MANUAL**,
- **CAR P**,
- **PID CAR**,

and other parameters as described in the **MENU** section.

7. Exit the menuWhen the setup is complete, exit the settings menu.

8. Setting the operating temperatures Finally, set:

- temperature **T** to which the system is to aspire,
- alarm temperature **Ta**.

After completing the above steps, the device is ready to work.

Below are examples of settings.

Distillation	Smoking
T=79degrees	T=80degrees
Ta=97degrees	Ta=50degrees

9. Start the process.

10. Observe temperatures during the first process.

In the case of underheating, the Pmin coefficient should be increased.

In case of overheating, the parameters should be reduced.

The temperature difference mainly depends, for example, on the height and place of mounting the analogue and digital sensors.

What is the easiest way to find the minimum power for automatic mode?

Set the MANUAL mode. Temperatures "T" and "Ta" set to 110 degrees.

We carry out the process in MANUAL mode. At the beginning, we set the power to 100%. Then, as we approach the expected temperature, we reduce the current power. After obtaining the expected temperature and system stability, we read the current power, e.g. 32%.

We prescribe the current power as a minimum power a few percent less, e.g. 26%. We can then switch to Auto P mode

What is the easiest way to designate Ta?

We carry out the process with the setting Ta=110. When we want to finish the process (distillation or smoking), we read the Ta temperature and enter it as a setpoint. From then on, when Ta reaches the same level, the driver will end the process.

NOTE: In distillation, in the case of tests "on water", the above parameters are incorrect, because the evaporation temperature of alcohol is about 78.4; not 100 degrees. Water can be boiled, but when the END sign is displayed, you must complete the tests on the water and carry out the process on the mash.

POWER FACTOR CALIBRATION AND ADJUSTMENT

To ensure the accuracy of the process, the user can calibrate the probes himself.

Hold down the center button for a longer time, after switching on the power supply, the user calibrates and adjusts the power factor.

By touching the "+" "-" fields, the WSP power factor is set. Confirm the setting by pressing the middle "O" button.

For the probe, the "+" "-" buttons set the linearity coefficient (straight slope) "B", which causes the indication $T_{\text{displayed}} = B * T_{\text{read from the sensor}} + A$. The setting is confirmed by the middle "O" button.

The temperature calibration window appears with an index of A.

Then, with the "+" "-" buttons, the "A" offset is set, which causes the indication of $T_{\text{displayed}} = B * T_{\text{read from the sensor}} + A$. The setting is confirmed by pressing the middle "O" button.

It is recommended to leave the default settings $B=1.25$ and $A=0$

"B" is adjusted when the difference between the temperature and the expected temperature increases or decreases as the temperature increases.

For example, at room temperature the temperature is lowered by 0.1 degrees, and at 80 degrees by 0.3 degrees.

"A" is adjusted when, with the increase in temperature, the difference between the temperature indication and the expected temperature is constant. For example, the temperature in the entire range is lowered by 2 degrees.

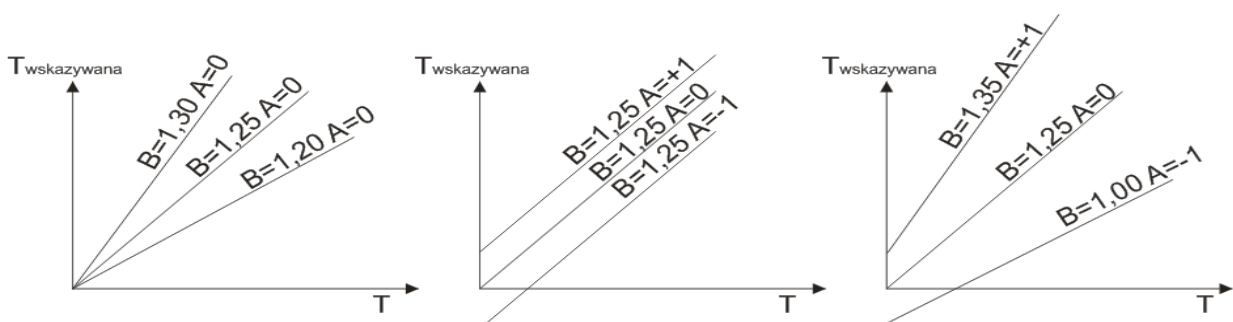

SYMPTOM	ACTION
The thermostat lowers the indicated temperature by a constant value, e.g. 2 degrees	Set the adjustment value A from "0" to "-2"
The thermostat inflates the indicated temperature by a constant value, e.g. 2 degrees	Set the adjustment value A from "0" to "2"
The thermostat lowers the indicated temperature, e.g. 10 percent	Increase the value of correction B, e.g. by "01", e.g. from "1.4" to "1.5"
The thermostat inflates the indicated temperature, e.g. 10 percent	Decrease the value of correction B, e.g. by "01", e.g. from "1.4" to "1.3"
A combination of the above	A combination of the above

The indicated temperature is the value of $T_{\text{displayed}} = B * T_{\text{read from the sensor}} + A$ and depends on the adjustments set.

Default :A=0 B=1.25 (in some versions the parameters may be replaced).

The device is delivered pre-calibrated. If your thermometer shows 19 degrees, it does not mean that this temperature prevails throughout the room. **The temperature difference mainly depends on the height and place where the sensor is mounted**, e.g. a different temperature is in a room closer to the radiator, near the floor, ceiling, wooden or metal element or by a window.

An analogous temperature behavior is in the device (distiller, smokehouse). The temperature may vary depending on the installation location, mounting method, thermal conductivity, etc. That's why we left you the option of manually calibrating the probes.

Calibration of the probe is not necessary.

NOTE!! The temperature of boiling water in a kettle is almost never 100.00 degrees. It should not be used as a calibration benchmark.

TECHNICAL PARAMETERS

Supply Voltage: 230V -20% +10%, 50Hz

Operating temperature: -10 to +60°C

Load capacity: 4.5kW PRD2 (3x4.5kW PRD2F)

Maximum power consumption: 1.5W

Power Adjustment Resolution: 0.25%

Temperature setting range: 10 to +130°C

Temperature Measurement Resolution: 0.05degree

Dimensions: L-150mm, W,-155mm, H-60mm (PRD2+)

Housing: Self-extinguishing plastic

Protection Grade: IP20

Compliance with standards:

PN- EN 60529

Lead-free (Pb-Free)

The basic version of the product is delivered without probes. This is due to its wide functionality.

Probes are options. The device has the ability to connect up to two probes.

The maximum power designation can be found on the warranty seal.

The device can be sold with power cables in place. This is an additional equipment for the controller.

CONNECTION DIAGRAM

NOTE!!!

**'PE' MEANS
PROTECTIVE WIRE
CONNECTION
NOT REQUIRED
FOR PROPER OPERATION**

**ENTRANCE MARKINGS
230V "L" and "N" POWER SUPPLIES
THEY ARE SYMBOLIC
THE DEVICE WORKS
REGARDLESS**

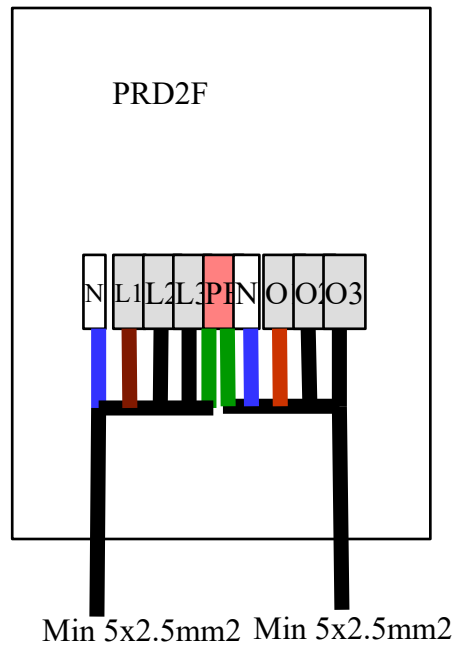
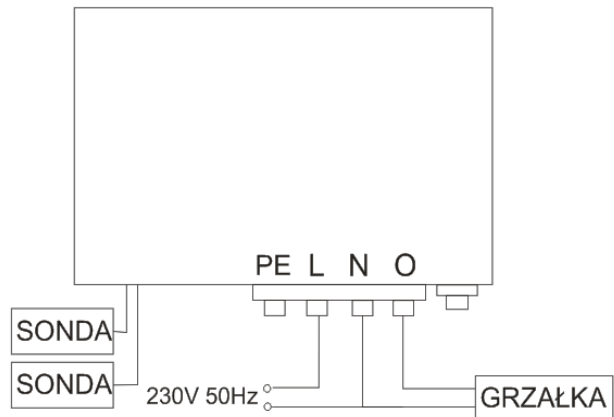

BEFORE YOU CALL

Symptom	Hint
The tank does not reach the correct temperature	In PID mode, increase the WSP factor. Replace the heater with a heater with a higher wattage. Increase the minimum power of Pmin
The heater does not turn off	Check that the "O" and "L" terminals have not been replaced. Check if the heater is in working order. After consulting with PAMEL service, check the fuse on the controller motherboard. The measured temperature is higher than the set temperature.
Dim the light	The dimming of the light is caused by overloading the electrical system. Each 1kW of heater power is an additional current of up to 5A, which can cause voltage drops with an old installation or thin wires. You should check the fuses in the apartment.
The device displays a temp of 0 degrees	The probe must be plugged in before the power is turned on. Turn off the device, wait a few seconds, then turn on the device. Check if the inscription "SENSORS 1 or SENSORS 2" appears during start-up.
In AUTO mode, the power is still 0%	Set WSP Power Factor The measured temperature is higher than the set temperature.
The controller is warm	The device is working properly. Most amplifiers, TVs, mobile phone chargers are warm. The device has thermal protection. If the temperature is too high, the controller will automatically turn off the control.
The controller is very hot, no control.	The device has a maximum power limit. Electric heaters are manufactured with different tolerances, e.g. 10 or even 20%. This means that, for example, heaters with a total power of 3.5KW can load the device with a power of almost 4kW (at 10% tolerance). If the heaters are not tested to consume a

	<p>maximum of 3.5 kW, a certain amount of power should be used.</p> <p>Some heaters are manufactured with a tolerance of up to 20%.</p>
<p>During measurements with the meter, strange values come out.</p>	<p>The output needs a load of at least 50W to work properly, otherwise the triac is triggered incorrectly. It should also be remembered that it is a power regulator, not a voltage regulator. I.e. the power of 50% does not mean the voltage at the output of 115V.</p>
<p>The probe does not work or "Probe error"</p>	<p>Check the number of probes detected during startup FEEL:number of probes Connect the probes one at a time and check if both are detected. Remember to change the KOL SOND to 0</p>
<p>No temperature-related settings (displays only the power P)</p>	<p>The probe must be plugged in before the power is turned on. Turn off the device, wait a few seconds, then turn on the device. Check if the inscription "SENSORS 1 or SENSORS 2" appears during start-up.</p>
<p>Detects one probe but T=0</p>	<p>Reorder the KOL probes. PROBE at 0</p>
<p>Cannot set power to 0 or 100%</p>	<p>You probably set the wrong minimum and maximum power values, e.g. the same values. Go to settings.</p>
<p>The display says END and the controller stops heating.</p>	<p>The actual temperature has risen above the set temperature. The driver has completed the process. Increase the set temperature T_a. Before this step, think about whether you are doing it consciously. Especially when trying to "on the water". Page 11</p>
<p>There is voltage at the output of the controller (power or valve) all the time.</p>	<p>Unfortunately, this is caused by inattention when connecting or by spilling liquid.</p> <p>The outputs in the controllers are at least twice as large. That is, at the output of the "pluses" there are</p>

<p>Does not turn off the heater (heating)</p>	<p>BTA41 triacs, which are designed for 40 AMPERS.</p> <p>In addition, the outputs are galvanic insulated, and the triac foot has ONLY CONTACT with your heater. That is, the output circuit in terms of electrical means resembles a contactor.</p> <p>If someone does not believe it, they can go to a trusted electronics service and ask about an analogous situation with connecting speakers to an amplifier, 99.99999% is caused by the wrong treatment of the output, not the fault of the device.</p> <p>Repairs of such damages are paid (flat fee 20 PLN + cost of components)</p>
<p>The controller does not maintain the set temperature</p>	<p>The controller is not a complicated device and cannot suddenly become de-adjusted.</p> <p>The temperature stability is influenced by:</p> <ul style="list-style-type: none"> - supply voltage (in winter it drops to 200V (heating), in summer it increases to 260 (photovoltaics)) - outdoor temperature (summer, winter) - replacement of materials in the column (scourers), dirt on the column, or the way of arranging springs or scourers. <p>The only variables are the environment and the mechanics of the colymna. For this reason, please do not send the driver for a complaint. Parameters such as the minimum power within a few years should be adjusted by the user, adapting to changes. If the controller is functional, i.e. regulates the power, we are not able to set it to an unknown column in the workshop, and each one is different.</p>

Any hose connections, if not properly made and carefully maintained, can cause melting due to excessive heating.

The cause of this phenomenon is the loosening of the metal contacts as a result of damage to the terminals or their corrosion, or insufficient tightening of the terminals.

Similar effects can also be caused by sparking in the multi-core duct in which the vein has been broken. Such a place heats up quite strongly and the resulting sparks can melt the insulation.

There are no jokes with 25A current, so please pay attention to the correct tightening of the terminals.





Any hose connections, if not properly made and carefully maintained, can cause melting due to excessive heating.

The cause of this phenomenon is the loosening of the metal contacts as a result of damage to the terminals or their corrosion, or insufficient tightening of the terminals.

Similar effects can also be caused by sparking in the multi-core duct in which the vein has been broken. Such a place heats up quite strongly and the resulting sparks can melt the insulation.

It is best if the ends of the wires are whitewashed or in ferrules.

There are no jokes with 25A current, so please pay attention to the good tightening of the terminals.

Alternatively, you should purchase a controller with a set of cables.

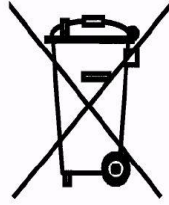

As professionals, we operate legally, which is why our products are registered with the Chief Inspector of Geosciences under number BDO000073814. **By buying equipment from us, you do not run the risk of control problems.**

Once you have used up your purchased items, you have the right to take them to a disposal point in your own city or send them to us.

When you resell unregistered equipment, you are responsible for placing it on the market. There is a penalty of PLN 5000 and upwards. Calculate whether it is worth the risk or whether it is better to buy a registered, legal device from us.



All our products have a certificate or declaration of conformity. All devices are subject to high standards

and it is not allowed to introduce devices that do not meet these conditions. Devices that meet the standards are easy to distinguish by the CE mark.

In Polish, it is not allowed to sell devices without meeting these two conditions. Otherwise, it means that there is a reason for circumventing the standards, and the company is operating illegally.

UWAGA !!!!

Prosimy o używanie
jak przyrządu pomiarowego



NIE CIĄGNAĆ ZA PRZEWÓD
WYCIĄGAĆ WYŁĄCZNIE
ZA GUMOWĄ OSŁONĘ CZUJNIKA



USZKODZENIA MECHANICZNE NIE PODLEGAJĄ REKLAMACJI

The probes are additional accessories and are subject to natural wear and tear. Therefore, these elements are covered by a standard warranty (not 5 years)

In addition, it should be remembered that threaded probes are a whole. Do not tear the sensors out of the metal covers.

This will void the warranty.

From 09.2021, all probes have a warranty seal indicating the date of manufacture. Destruction of the seal is considered to be erasure of the marks identifying the product

ONLY REMOVE THE PROBES WHEN THEY ARE COLD. NOT ALLOWED TO PULL THEM OUT "HOT"



https://www.youtube.com/@PAMEL_STEROWNIKI/

Dear User,

First of all, we would like to thank you for choosing a PAMEL product. We are sure that you will be satisfied with this choice. We design our devices to meet your requirements and guarantee future trouble-free use.

Before using the equipment, carefully read the installation procedures and operating conditions described in the Owner's Manual.

If you have any doubts, please contact us.

453-343-360 (OFFICE 9-14 weekdays)

453-343-360 (Technical Support 16-19 Monday-Saturday)

WARRANTY CONDITIONS

1. PAMEL provides a warranty for the controller (without additional equipment) in the Republic of Poland for a maximum period of 60 months:

- **24 months basic warranty,**
- **6 months extended manufacturer's warranty,**
- **In addition, it is possible to purchase a warranty extension of up to 40 or 50 months.**

The total warranty period must not exceed 80 months from the date of manufacture of the device. Additional equipment (e.g. probes, heaters) is covered by a standard warranty resulting from the Civil Code.

The purchased warranty extension is confirmed by a hologram sticker on the warranty card.

- 2. The warranty does not cover consumables and accessories intended for self-assembly (e.g. antennas, sensors, holders, heaters, cables, batteries).**
- 3. During the warranty period, the manufacturer undertakes to remove physical defects free of charge. If at least four repairs have been carried out under the basic warranty and the device is still defective, the Buyer has the right to exchange it for a new copy with equivalent parameters or to a refund.**
- 4. The warranty period is extended by the duration of the repair.**
- 5. Complaints should be submitted by e-mail (pamel@pamel.pl) or by phone. The manufacturer will first try to solve the problem remotely and indicate further complaint steps.**
- 6. At the manufacturer's request, the Buyer is obliged to fill in the complaint protocol.**
- 7. The warranty covers only defects caused by the device.**
- 8. The warranty does not cover damage resulting from:**
 - **improper installation, operation or maintenance,**
 - **storage in inappropriate conditions,**
 - **use of improper consumables,**
 - **independent repairs or modifications,**
 - **mechanical damage, flooding, condensation of water vapour, pollution, atmospheric phenomena, random events,**
 - **exceeded the nominal parameters.**
- 9. The warranty does not cover claims regarding the technical parameters of the device, as long as they are in accordance with the manufacturer's data.**
- 10. The condition for maintaining warranty rights is the delivery of the device:**
 - **in complete condition,**
 - **in packaging that protects against damage,**
 - **with documentation, cables and additional elements,**
 - **without removed or damaged seals and stickers,**

- with the original warranty card signed by both parties and a sticker with the date of manufacture.
11. The warranty does not cover services and materials related to normal operating (e.g., assembly, programming, cleaning, maintenance, replacement of fuses and bulbs). These services are charged.
 12. The Service may refuse to perform a warranty repair in the event of:
 - inconsistency of the data in the documentation with the actual state of the device,
 - unauthorized amendments to documents,
 - remove device identification marks (e.g. stickers).
 13. Warranty repairs are carried out within 21 days from the date of delivery of the device for service. If it is necessary to import a part from abroad, this deadline may be extended – the Buyer will be informed about it by e-mail.
 14. Installation of the appliance must be carried out in accordance with the standards and the operating instructions. If required by law, the installation must be carried out by a person with the appropriate permissions.
 15. The scope of the rights and obligations of the parties is governed exclusively by this document.
 16. Equipment not collected from the service within 3 months of the completion of the repair becomes the property of the service.
 17. The parts replaced during the repair remain the property of the manufacturer.
 18. The manufacturer is not responsible for the loss of user data stored on the device. After repair, the device is returned in a state restored to factory settings.
 19. By signing the warranty card, the buyer confirms that he has read the terms of the warranty and accepts them. A card without a signature and without an original sticker with the date of production is invalid.

Note: The number of repairs does not include maintenance, cleaning, replacement of bulbs, fuses, wear and tear or repairs resulting from natural wear and tear (e.g. potentiometers).

WARRANTY START DATE	SELLER STAMP	CUSTOMER SIGNATURE

19.04.2026